

REDPATH LOCKSTRIP & INSTALLATION / USER GUIDELINES

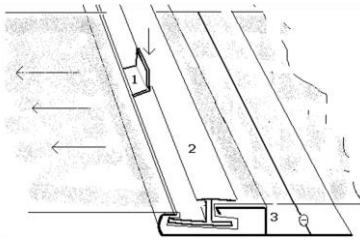

To be read in conjunction with

- a) Redpath greenhouse cover handling guidelines
- b) Redpath greenhouse cover installation guidelines
- c) Redpath suppliers statement in current catalogue



- (1) Locking Clip, 125/150mm apart
- (2) White U.P.V.C insert.
- (3) Alloy Base

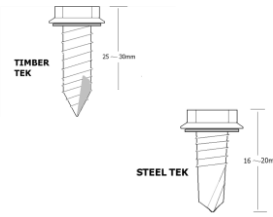

Steel or Timber fastening screw with neo washer

OTHER LOCKSTRIP PROFILES AVAILABLE

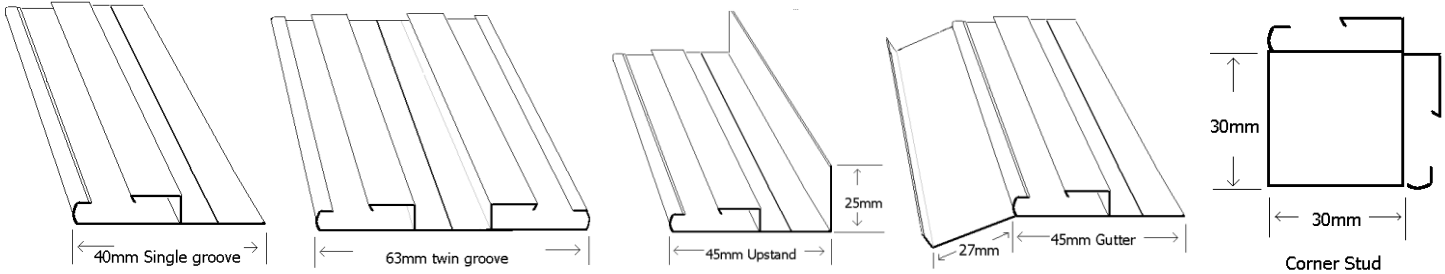

Fastening Screws

Steel 12 x 20mm x Timber 12 x 25/30mm are most commonly used. Experience indicates that a screw with a galvanized coating of approximately 40 microns with a neoprene washer is sufficient. Screw spacing @ 150mm–200mm. If screws are to be exposed to higher than expected corrosion levels i.e. foundation or gutter areas, a longer life fastener should be considered. If in doubt please check with your lockstrip supplier. Note: Screw spacing may reduce for very large covers or in high wind area.

Positioning Base Profiles

Typically the lockstrip system is located around the perimeter edge of the cover being held, however it may also be used for joining covers on rafters, top rails etc. Using the correct screws fix the lockstrip in a continuous strip to a structural beam or rail* with rounded edge facing toward cover. Take care to align the profile grooves at any joints & also to keep groove clear of dirt & debris. Note: If fixing lockstrip to a galvanized steel rail ensure a barrier membrane is provided to prevent electrolysis. The Lockstrip base should overlap any structural joints. Lockstrip should not be used to form gutters or be fixed in a position where water can pond.

Typical Lockstrip Locations

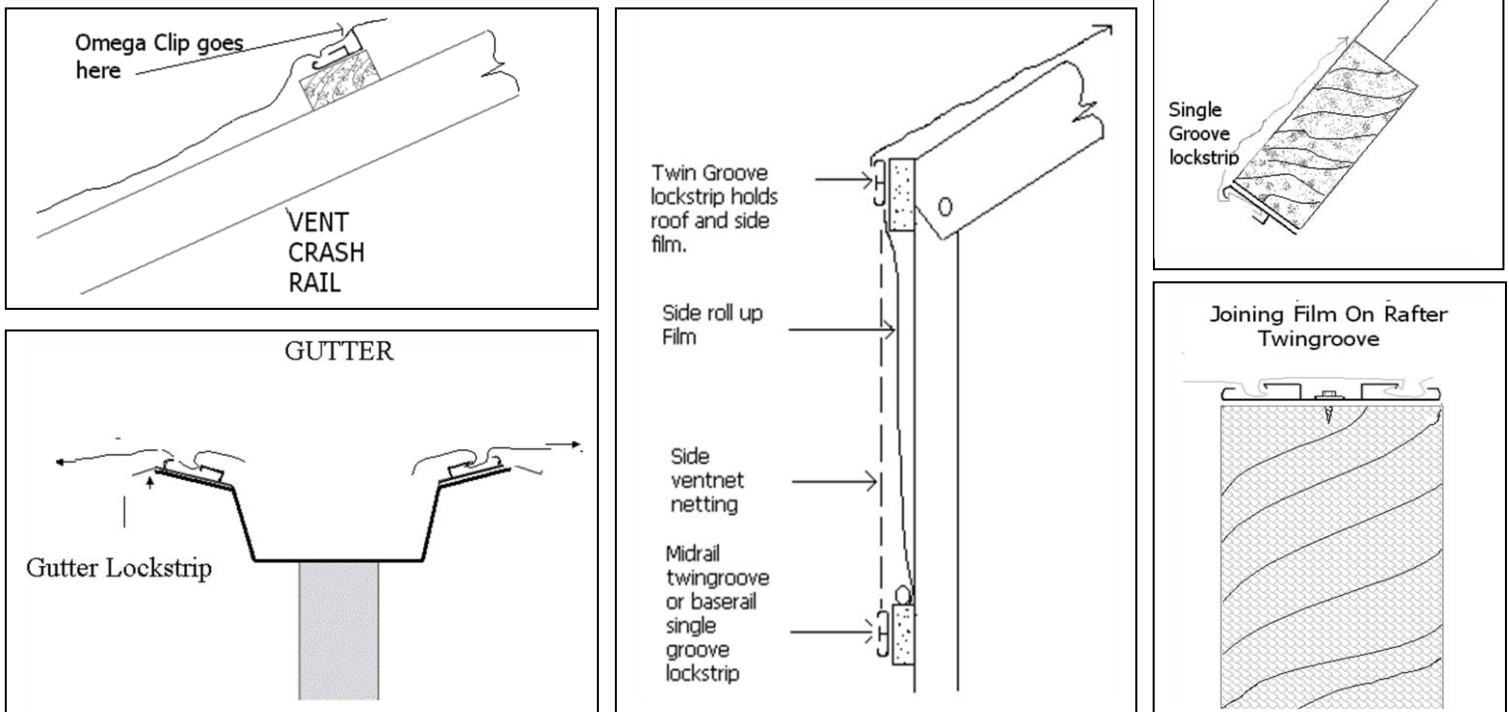

Lockstrip Assembly

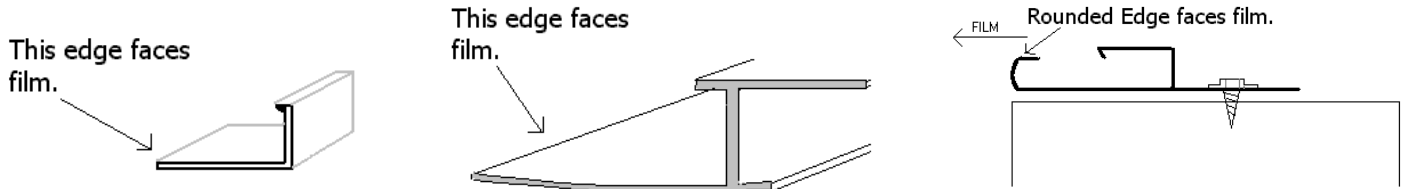

The drawing above shows the direction of the three lockstrip components. The longer leg of the clip & the insert plus the rounded edge of the aluminium base always faces toward the cover being held.

Lockstrip Cover Width Tolerances

Experience suggests that in a medium wind zone on a sheltered site, the following sheet widths would be acceptable. These recommendations are based on a 5 year wind return period.

Maximum Roof Sheet Width
on truss 6m

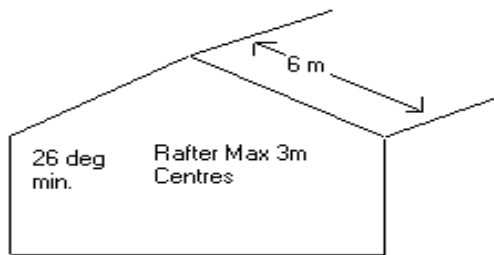

*Singleskins batten each 3m
Twinskins – note instructions*

Maximum Roof Sheet Width
on arch 9m

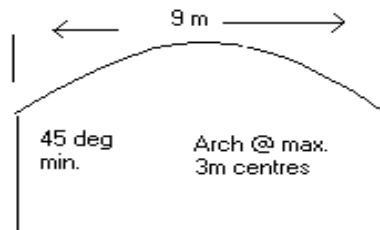

*Singleskins 200mu cover
Twinskins: note instructions*

NOTE: Read Redpath cover installation guidelines before installing cover. Greater widths than those listed above, may be used, however, consultation with your supplier & your design engineer will be needed.

LOCKSTRIP COVER CLIPPING PROCESS

Always begin any clipping in middle of sheet and work toward corners. Read Redpath cover installation & cover handling guidelines before proceeding.

- Use a batten or similar to roll the cover edge and draw it across the lockstrip groove.
- Position a length of white insert (tilting it forward slightly) above the cover & lockstrip groove.
- Press the insert gently down whilst slightly relieving cover tension from behind.
- Ensure that the insert is seated back in alloy groove & locate a locking clip, every 125/150mm apart.
- Repeat process for all inserts/clips for full length whilst maintaining a constant length “tag” of cover behind the lockstrip.

Helpful Hints:

The white insert should clearspan any aluminium joins.

Do not apply tension to “tag” of cover behind lockstrip once insert installed & clipped

To ease locking clip installation press white insert firmly the lockstrip

Avoid placing locking clips directly on wrinkled or bunched up cover

Always locate a locking clip within 50mm of all white insert ends

Snip corners from insert as shown below to aid insertion

Leave a minimum of 75mm of excess tag cover behind back into groove.

Position locking clips initially with thumb & then press home with a soft tool

Ensure that alloy groove is clear of dirt & debris.

Keep locking clips warm to aid flexibility & ease installation

