

# Ridder Drive Systems B.V.

Lorentzstraat 32  
3846 AX Harderwijk  
PO Box 360  
3840 AJ Harderwijk  
the Netherlands

T +31 (0)341 416 854  
F +31 (0)341 416 611  
I [ridder.com](http://ridder.com)  
E [info@ridder.com](mailto:info@ridder.com)



## Product Manual

# Ridder Motor Gearboxes RW 1-phase

Original product-manual  
265001EN - 2021.12 - V01

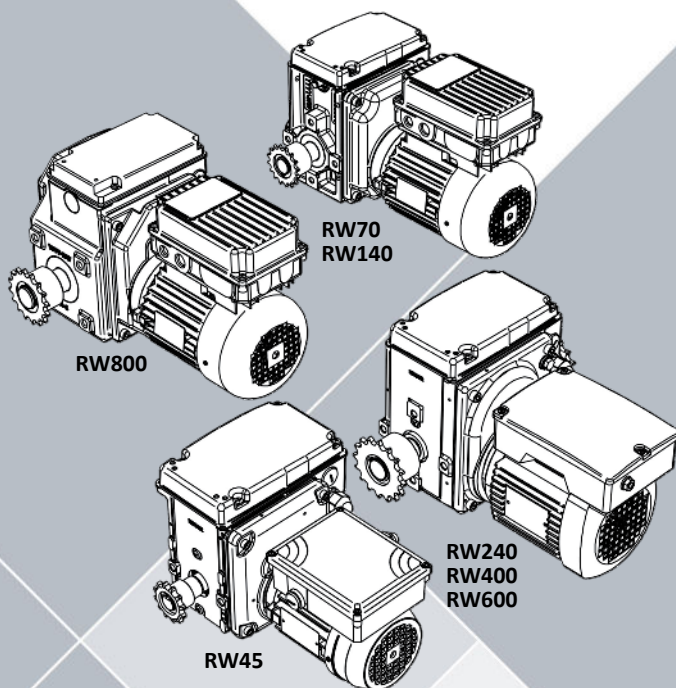

Helping you grow  
**your way**



## TABLE OF CONTENTS

<b>1. GUIDELINES, STANDARDS AND CONDITIONS</b>	
1.1 Applicable guidelines and standards	3
1.2 Approved personnel	3
1.3 Warning about discouraged use	3
1.4 Warranty provisions	3
<b>2. SAFETY, PRECAUTIONS AND SYMBOLS</b>	
2.1 Signal words, instructions and warnings	4
2.2 Precautions and safety instructions	5
2.3 Residual risks	6
2.4 Symbols and abbreviations	7
<b>3. PRODUCT DETAILS</b>	
3.1 Identification	8
3.2 Description	9
3.3 Application	10
3.4 Dimensions	11
3.5 Technical specifications	13
<b>4. INSTALL INSTRUCTIONS</b>	
4.1 Special tools and equipment	15
4.2 Mounting positions	15
4.3 Sprockets	18
4.4 Installation	19
4.5 Installation options A–F for output shafts	23
4.5.1 Basic output shafts (BOS)	23
4.5.2 Special output-shafts (D, LD, LK ....)	23
4.5.3 Installation chain (for A–D)	24
4.6 TRA drive-unit onto RW45\240TRA motor gearbox	25
4.7 Belt drum onto RW45\240/400L motor gearbox	27
4.8 Cable drum onto RW45\240/400L motor gearbox	28
<b>5. CONNECT INSTRUCTIONS</b>	
5.1 Removal covers	29
5.2 Electrical material	30
5.3 Protection - Conditions and starting points	32
5.4 Tightening-torque motor-connections	33
5.5 Control-circuit connection - 3-wire [RLS]	34
5.6 Motor-current connection - 3-wire [RLS]	35
5.7 Control-circuit connection - 5-wire [RSU]	36
5.8 Control-circuit connection - 5-wire, Alternative [RSU]	37
5.9 Change Direction-of-rotation - Switching sense	38
5.10 OPTIONAL - Position Feedback	38
<b>6. USER INSTRUCTIONS</b>	
6.1 Usage - Conditions and starting points	38
6.2 Direction-of-rotation RW motor-gearboxes	40
6.3 Operation	42
6.4 Safety functions and stop functions	42
<b>7. COMMISSIONING INSTRUCTIONS</b>	
7.1 Commissioning - Conditions and starting points	42
7.2 RLS/RSU limit-switch system	43
7.3 Adjusting the end positions	45
7.4 Installation covers	46
<b>8. MAINTENANCE INSTRUCTIONS</b>	
8.1 Maintenance	47
<b>9. SERVICE</b>	
9.1 Troubleshooting	48
9.2 Technical support	49
<b>10. ENVIRONMENT</b>	
10.1 Decommissioning and removal	49
10.2 Waste disposal	50



**Ridder Drive Systems B.V.**

T +31 (0)341 416 854 - F +31 (0)341 416 611 - I [ridder.com](http://ridder.com)

# 1. GUIDELINES, STANDARDS AND CONDITIONS

## 1.1 Applicable guidelines and standards

This product complies with the provisions of the European guidelines that follow:

Machinery Directive 2006/42/EC | Low Voltage Directive 2014/35/EU

The harmonized standards (or parts of these standards) that follow are applicable:

NEN-EN-ISO 12100:2010 | NEN-EN-IEC 60204-1 |

NEN 82079-1 (62079: 2001) | NEN5509 | ISO 3864-2

**Make sure that this product is only put into operation if the system (in which it will be installed) complies with the provisions of the applicable standards and guidelines.**

Regulatory Conformity



## 1.2 Approved personnel

This product manual contains important information for installers about the installation and commissioning of a Ridder RW motor-gearbox. Read this product manual and instructions first before the work starts. Approved mechanical and/or electrical installers, with professional competence, must do all work safely and responsibly.

TARGET GROUP FOR EACH CHAPTER	CHAPTER (refer to Table of Contents)									
TARGET GROUP	1	2	3	4	5	6	7	8	9	10
User (operator)	•	•	•			•			(•)	(•)
Installer / Approved personnel	•	•	•	•	•	•	•	•	•	•

(•) = Not fully applicable (for users/operators)

Keep this product manual with the product during the lifespan. Make sure it is available for users (operators), installers and approved personnel.

## 1.3 Warning about discouraged use

The conditions that follow are applicable:

- Do not change (the construction of) the RW motor gearbox.
- It is not permitted to weld to the RW motor gearbox or its parts.
- It is not permitted to use the RW motor gearbox to lift or move people.
- Do not let the torque of the RW motor gearbox be more than its maximum.
- Do not let the duty cycle of the RW motor gearbox be more than its maximum.
- It is not permitted to use the RW motor gearbox in operating conditions, systems or configurations which do not comply with the technical specifications (in this manual). Also refer to §3.5.

Refer to §3.3 for a description of the intended use.

## 1.4 Warranty provisions

For the warranty period and conditions refer to the 'Conditions' section on our website at [ridder.com](http://ridder.com), or in the Ridder catalog.



**Ridder Drive Systems B.V.**

T +31 (0)341 416 854 - F +31 (0)341 416 611 - I [ridder.com](http://ridder.com)

## 2. SAFETY, PRECAUTIONS AND SYMBOLS

### 2.1 Signal words, instructions and warnings

#### Signal words (ISO 3864-2)

This product manual contains safety instructions with different signal words. The list that follows gives the risk levels and possible effects of each signal word.



Suggestion to perform an operation more effectively.



May result in damage or problems if an action is performed incorrectly.



May result in minor injury if the hazard is not avoided.



Significant injury, possible death, if the hazard is not avoided.



Severe injury and possible death if the hazard is not avoided.

#### Instructions and warnings on the product



Read the product manual to fully know all product properties, before it is used or work starts!

It is not permitted to use high-pressure cleaners (and related cleaning agents)! Use a soft brush with a small quantity of water without cleaning agents.

Warning - Electrical voltage

After installation interchange the plug in the highest position with the vent plug! Refer to the permitted mounting positions in the product manual.\*

\* Not applicable to motor gearboxes filled with grease!

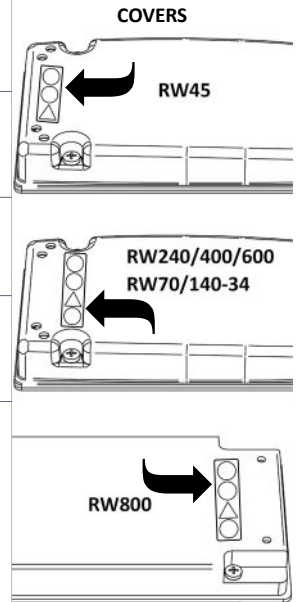

## 2.2 Precautions and safety instructions

---

### Precautions

#### GENERAL

A system can be dangerous. Safety precautions and instructions are important.

- If these precautions cannot be obeyed, then use warnings.
- The responsibility for precautions and warnings lies with the installer of the system. Refer to the, local or national, laws and regulations of the country if a certification (mark) is necessary.
- Parts of the electrical or electronic installations are connected to dangerous electrical voltages. This is also applicable if the drive unit is not in operation or the motor does not turn. Work without professional competence or not obeyed warning instructions could cause injury and/or material damage.
- Make sure that no foreign particles, loose parts, moisture or dust go into the components (EM, gearbox, RLS/RSU) during all work. There is a risk of short circuit, fire and corrosion.
- Take sufficient precautions to prevent ElectroStatic Discharge (ESD).
- Ridder is not responsible for injury, material damage or consequential damage if accessories are used that Ridder did not make.

#### TRANSPORT, STORAGE AND PACKAGING

The conditions and instructions that follow are applicable.

- Ambient temperature: -15 to +60 °C (+5 to +140 °F).
- Ambient: A not-condensed relative humidity is necessary.
- Do a check for transport damage and missing parts immediately on incoming goods.
- Tell damages and missing parts immediately to the transport company and to your local After Sales contact person.
- Do not use damaged products and if necessary do not start the work.
- Do not remove the product from the (sealed) packaging before it is sent to the installation site. This prevents damage (from mechanical shocks) to the product.
- Use applicable means-of-transport with dimensions which are sufficient. Use (if necessary) the correct work equipment and accessories. Refer to “Dimensions” and “Technical specifications”. Make sure that the working conditions comply with the, local or national, laws and regulations.
- Make sure that storage areas and the areas in the means-of-transport are dry and the airflow is sufficient.
- Make sure that the products do not touch the (moist) bottom surface of storage areas and of the means-of-transport (use pallets or such). The bottom surfaces must be smooth.
- Make sure that the products are protected from dust, dirt and direct sunlight.
- Apply an applicable corrosion-preventive agent to metal surfaces that are not painted.
- After installation discard the packaging and obey the applicable national and/or local regulations.



**Ridder Drive Systems B.V.**

**T +31 (0)341 416 854 - F +31 (0)341 416 611 - I [ridder.com](http://ridder.com)**

## Safety instructions



**If you do not obey the safety instructions that follow it can be dangerous and cause injury.**

- **For a fail-safe function install redundant safety systems to prevent that loads or system parts fall uncontrolled. Install (if necessary) protection from system parts that move. Obey the applicable national and/or local standards and guidelines of the related type of operated system.**
- Use (if applicable) personal protective-equipment for protection which agrees with the different types of work.
- Do not let persons and not approved personnel be near controls and systems in operation.
- Damaged systems must be stopped immediately until they are repaired.
- Use safety barriers for system parts that move. Refer to the applicable standards and guidelines.
- The safety distance to the danger zone (if applicable) must agree with applicable standards and guidelines (for example ISO 13857:2008).
- Do not operate systems when the motor gearbox (internally and/or externally) is frozen in cold and moist conditions (for example because of snow or ice).
- Do not operate systems when persons are in the danger zone and can touch the system.
- Monitor the danger zone when you work with or near the system.
- Stop and de-energize systems during maintenance and cleaning work on or near the system.
- Make sure that there is sufficient space between parts that move and adjacent objects.
- Stay away from or safety areas where there is a risk to become caught in a system that moves.
- The torque and the duty cycle of the system must be in the range of the motor gearbox parameters.

### 2.3 Residual risks

---

#### Automatic controls

The Ridder drive-units are usually used in automatic controlled systems. Persons who do work or stay near the system must know about that. If persons or their clothes touch the system during operation, it can be dangerous.



**Persons can be in danger of life if they touch a system that is in operation.**

#### Forces

Ridder cannot be sure that there will be no injury to persons or damage to the system because of the forces in the systems (in which the drive unit is installed).

## 2.4 Symbols and abbreviations

This section tells about used symbols and abbreviations in this manual. The table that follows gives the descriptions.

Symbol	Description	Symbol	Description
ACS	Automatic control-system	PLC	PLC Control
BOS	Basic Output Shafts (RW)	PTO	Thermal-overload protection-switch
C	Common connection	PZ	Cross head "Poqidriv"
D	Model with continuous worm-shaft	P21/1	Auxiliary contact K21
EM, M	Electric motor, Motor	P22/1	Auxiliary contact K22
EMC	Electromagnetic compatibility	P71, P72	Automatic-control contacts (ACS)
ESD	ElectroStatic Discharge	RLL	Ridder LogicLink
ES11,ES12	Duty switch RLS/RSU	RLS	Limit-switch system
ES21,ES22	Safety switch RLS/RSU	RMC	Ridder MotorControl
F1	Fuse	rpm	revolutions per minute
HEX	Hexagonal width-across-flats	RPT	Ridder PolyTelescope
I	Current in Amperes (A)	RPU	Ridder PositioningUnit
IP	International Protection Rating	RRD	Ridder RackDrive
K	Designation sprocket (assembled configuration)	RSD	Ridder ScreenDrive
kb	Maximum running time in minutes (kb = KurzBetrieb/ Short operation)	RSU	Limit-switch system
K11	Auxiliary relays (safety switches)	RW	Motor gearbox
K21, K22	Reversing relay (sufficiently specified) for direction-of-rotation	SBI	Standard Bolt-Installation
K81	Auxiliary relay: 1-phase, 3-wire to 5-wire	SID	Screw-in depth
L	Model with winch shaft	SS (S21)	System switch (S21)
L1	Voltage source	SW	Width-across-flats
MC	Manual Control	S11	Manual switch (bridged safety circuit)
MPCB/ Q41	Motor-Protection Circuit-Breaker	S21 (SS)	System switch (SS)
N	Neutral wire	S111	Manual switch (MC)
NC	"normally closed"	TRA	Model for built-on rack unit
NO	"normally open"	TRI	Rack drives TRI
PE	Protective earth	TRN	Rack drives TRN
PH	Cross head "Phillips"	TX	Screw head "Torx"
		T1	Safety transformer (EN 61558)
		U1, U2	Motor connection
		V1	Motor connection
		W1, W2	Motor connection



### 3. PRODUCT DETAILS

#### 3.1 Identification

##### EXAMPLE



This product manual is only applicable to:

- Ridder Motor Gearboxes RW 1-phase
- Serial numbers from 200.900.000
- Item numbers from 500000.

##### COVERS

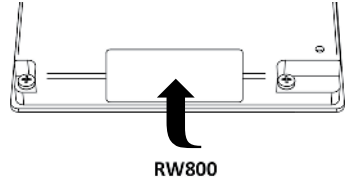
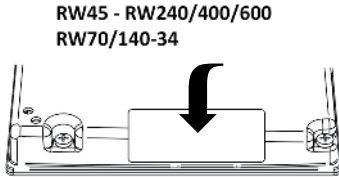

Identification is possible from the sticker on the location shown. Refer to the explanation that follows on how to read the information. For more information on item numbers and models refer to the Ridder catalog or website at [ridder.com](http://ridder.com).

RW241-1-L-09\115\1\60\PCU\86\IP55\z16\WI	WI: White color finish
	z16: Optional sprockets
	Alternatives: z12/3z16 (3x for D model)
	IP55: Protection rating
	No symbol in identification = IP54
	V: Grease lubrication
	No symbol in identification = Oil lubrication
	86: Limit-switch range motor-gearbox
	Alternatives: 55/97/120/860
	CU: CSA/UL certification mark
	Alternatives: 3C (CCC)/C (CSA)/U (UL)
	P: Thermal-Overload Protection-Switch (PTO)
	60: Mains frequency [Hz]
	No symbol in identification = 50 Hz
	1: 1-phase mains voltage
	115: Mains voltage [V]
	Alternatives: 230
	09: Motor power at 50/60 Hz [daW]
	Alternatives: 11/18/22/25/30/37/44/55/66/110/130
	L: Model with winch shaft
	TRA: Model for built-on rack unit
	D: Model with continuous worm-shaft
	No symbol in identification = Sprockets (K)*
RW45\RW70\140	1: Rotational speed of drive shaft at 50(60) Hz [rpm]
RW240-600\RW800	Alternatives: 2/3/5/34(41)
	240: Torque [Nm]
	Alternatives: 70/140/400/600/800
	45 = Torque 120, 90 or 60 Nm
	RW: General designation Ridder RW motor-gearboxes

----- = If not applicable: No symbol in identification.

**NOTE:** Possibly the sequence of symbols is different and/or other symbols are included in the identification. Not all symbols and assembled configurations (such as LK, LD, ...) are included in the explanation.

\* K = Sprocket in an assembled configuration.



Ridder Drive Systems B.V.

T +31 (0)341 416 854 - F +31 (0)341 416 611 - I [ridder.com](http://ridder.com)



### 3.2 Description

RW motor gearboxes are drive units to operate systems in greenhouses, livestock houses, crop-storage buildings and such. The RW motor-gearboxes are applicable at ambient temperatures between 0 and 60 °C. RW motor-gearboxes have a self-braking worm-gear transmission which stops the drive unit (worm shaft) when not operated and then locks the output shaft. To operate manually (externally) is possible with (electric) tools and a hexagon socket in the shaft of the electric motor.

The RW motor-gearboxes (1-phase) have the linear RSU or RLS limit-switch system, with duty switches and safety switches. 3-wire electric motors have thermal protection with a thermal-overload protection-switch (PTO). RW motor-gearboxes are applicable to use intermittently (duty class s3-35%) with a maximum duty cycle of 25 minutes. The optional PositioningUnit RPU monitors the positions of the drive unit and transmits the data to the automatic control-system (ACS). Position feedback is also possible with a mounting set with potentiometer. Operation is possible, usually in automated systems, with a manual control (MC) and/or other control components.

The RW motor-gearboxes have connections (terminal blocks/connection blocks) to connect the cables and are supplied with cable glands for the power cables and control cables. The gearbox housing of the RW motor-gearbox has a powder-coating. RW motor-gearboxes are supplied with fixing bolts and spring washers.

#### RW45 series

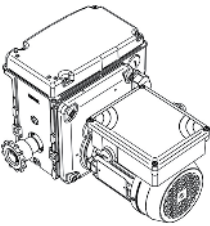

- **RW45:** 12-tooth 1/2"x5/16" zinc-plated sprockets for chain couplings are installed. **Optionally** 16-tooth 1/2"x5/16" sprockets are installed to compensate for larger angle differences (to a maximum of 6°).
- **RW45L:** Has a one-sided output shaft to install a belt drum or cable drum.
- **RW45TRA:** Has a one-sided output shaft to install a TRA520 rack-drive.
- **RW45D:** An RW45 with a continuous worm-shaft. **Optionally** a 16-tooth 1/2"x5/16" zinc-plated sprocket for chain couplings is installed.

The switching range of the limit-switch system is 55 or 97 revolutions of the drive shaft. The range is related to different models.

#### RW240–600 series

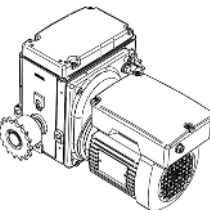

- **RW240/400/600:** 16-tooth 5/8"x3/8" zinc-plated sprockets for chain couplings are installed.
- **RW240/400/600L:** Has a one-sided output shaft to install a belt drum or cable drum.
- **RW240/400/600TRA:** Has a one-sided output shaft to install a TRA520 rack-drive.
- **RW240/400/600D:** An RW240/400/600 equipped with a continuous worm-shaft. **Optionally** a 16-tooth 1/2"x5/16" zinc-plated sprocket for chain couplings is installed.

The switching range of the limit-switch system is 86 revolutions of the drive shaft.

### RW800 series

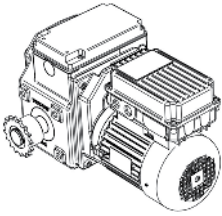

- **RW800:** 16-tooth 5/8"x3/8" zinc-plated sprockets for chain couplings are installed.

The switching range of the limit-switch system is 120 revolutions of the drive shaft.

### RW70/140

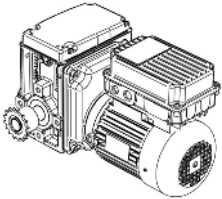

- **RW70/140:** 16-tooth 1/2"x5/16" zinc-plated sprockets for chain couplings are installed.

The switching range of the limit-switch system is 860 revolutions of the drive shaft.

## 3.3 Application



**Make sure that (with RW motor gearboxes) operated systems comply with the provisions of the applicable safety standards and safety guidelines.**

**This prevents (for example) the risk:**

- **To become caught in a system that moves**
- **That loads or system parts that fall can hit persons.**

- The RW45 motor gearboxes are drive units to operate ventilation systems and screen systems in greenhouses and livestock houses or crop-storage buildings.
- The RW45L\RW240/400L motor gearboxes with drums (belt or cable) are drive units to hoist feeding lines and drinking lines and to open air inlets in livestock houses or crop-storage buildings.
- The RW45TRA\RW240TRA motor gearboxes with a TRA520 rack drive are drive units to operate ventilation systems and hoisting systems in greenhouses and livestock houses or crop-storage buildings.
- The RW45D\RW400/600D motor gearboxes are drive units to operate ventilation systems and hoisting systems in greenhouses and livestock houses or crop-storage buildings.
- The RW240–600\RW800 motor gearboxes are drive units to operate ventilation systems, screen systems and hoisting systems in greenhouses and livestock houses or crop-storage buildings.

- The RW70/140-34 motor gearboxes are drive units to operate indirectly-operated ventilation-systems in greenhouses and livestock houses or crop-storage buildings.

This section tells about usual configurations of motor gearboxes and operated systems. Possibly other configurations (or applications) are applicable.

For other (different) applications, approval from **Ridder Drive Systems** is necessary.

### 3.4 Dimensions

The dimensions and illustrations are approximate. In this manual shown illustrations can be different than the components and/or systems.

#### RW45:

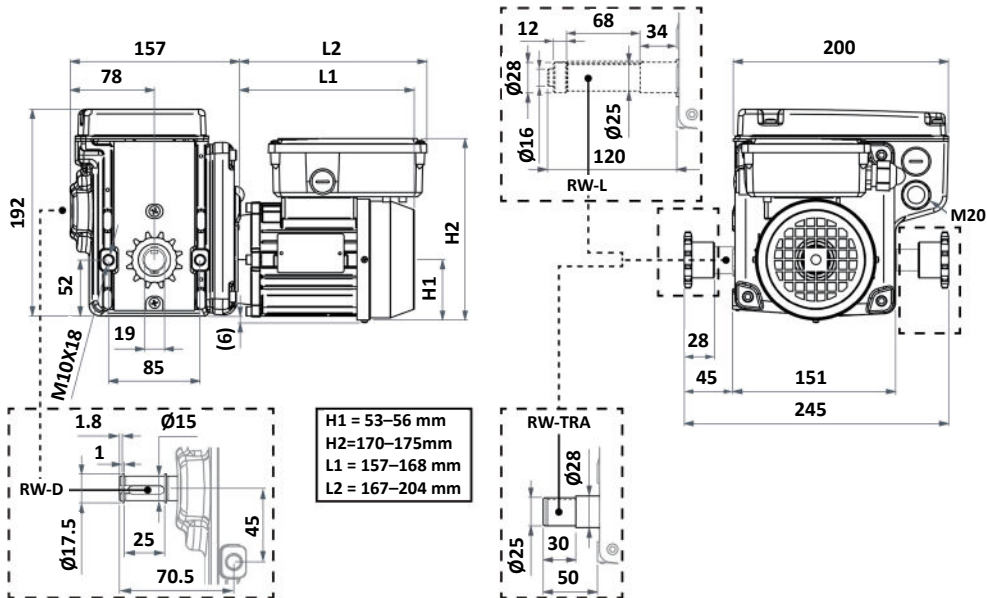

**Ridder Drive Systems B.V.**

T +31 (0)341 416 854 - F +31 (0)341 416 611 - I [ridder.com](http://ridder.com)



**RW70/140-34:**

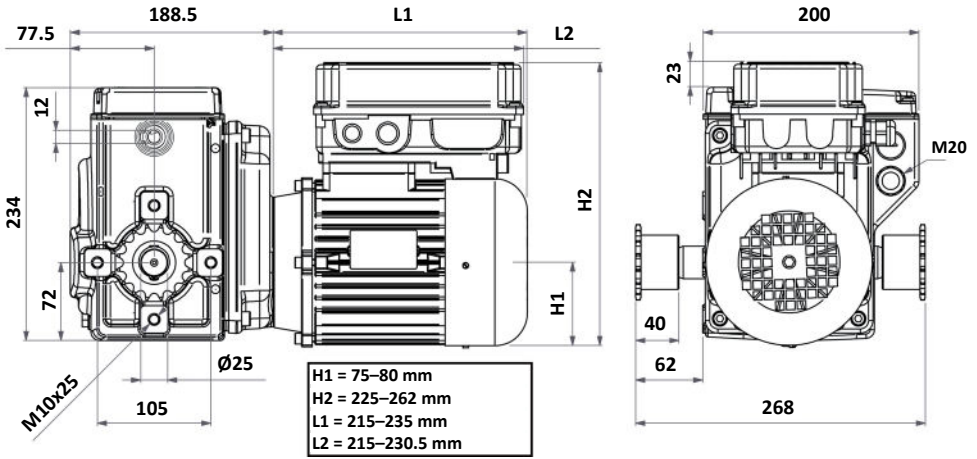

**3.5 Technical specifications**

**Mechanical**

RW series	RW45	RW240-600	RW800	RW70/140
Torque [Nm]	60 90 120	240 400 600	800	70 140
<b>Mains frequency [Hz]</b>	50/60		50/60	50/60
Rotational speed [revolutions per minute]	1/1.2* 2/2.4* 3/3.6 5/6.0		3/3.6 5/6.0	34/41
* Not applicable:	-	RW600	-	
Limit-switch range [revolutions of drive shaft]	55 97	86	120	860
Drive unit	Self-braking			
Operate manually (externally):	With (electric) tools and a hexagon socket in the shaft of the electric motor.			
Dimensions [mm] WxHxD	Refer to §3.4 (minimum-maximum).			
Weight [kg]	15.5-16.5	28.5-42.8	45	31-37



**Ridder Drive Systems B.V.**

**T** +31 (0)341 416 854 - **F** +31 (0)341 416 611 - **I** [ridder.com](http://ridder.com)

## Electrical

RW series	RW45	RW240–600	RW800	RW70/140
Duty cycle [kb]	Applicable for intermittent duty, duty class s3-35%, with a maximum running time of 25 minutes.			
Maximum current	Refer to the nameplate of the electric motor.			
Power				
Thermal protection EM [°C (°F)]	3-wire electric motors are thermally protected with a PTO switch with a switching temperature of 140 °C (284 °F).			
Cable glands	M16x1.5 mm/M20x1.5 mm. Also refer to §5.2.			

### Mains voltage

115 V - 60 Hz	•	•*	-	-
230 V - 50 Hz	•	•	•	•
240 V - 60 Hz				
* Not applicable:	-	RW600	-	-

## Ambient

RW series	RW45	RW240–600	RW800	RW70/140
Protection rating	IP54*			
Ambient temperature [°C (°F)]	0–60 °C (32–140 °F)			

\* IP55 only applicable if in identification.

## 4. INSTALL INSTRUCTIONS

Installation is only permitted to approved personnel.

Do a check of the supplied parts in the table that follows. Use these parts with the mounting plate (selection) which is applicable. Refer to §4.4.

Parts list *	
500000 Motor Gearbox RW 1-phase **	1x
* Minimum parts list: Motor gearbox <b>without</b> optional parts and accessories.	
** Motor gearboxes have spring washers and bolts M10x20 (2x), M10x25 (3x) or M12x25 (4x). Item numbers from 500000.	

### Installation (general)

- This product manual gives **only** information about the installation of RW motor-gearboxes and related connections to output-shafts (installation options).
- Information about the different operated systems is **not** (or not fully) given or gives only general information.



**Ridder Drive Systems B.V.**

T +31 (0)341 416 854 - F +31 (0)341 416 611 - I ridder.com

## Installation options for output shafts

Refer to (if applicable):

- §4.5.1 for the (most) used connections of **basic output shafts** to operated systems (installation options A–F)
- §4.5.2 for the installation options (A–F) of **special output shafts**
- §4.5.3 for the installation of **chains** onto sprockets (for installation options A–D)
- §4.6 for **TRA** models with TRA drive-unit (installation options G, H, I)
- §4.7 for **L** models with belt drum (installation option J)
- §4.8 for **L** models with cable drum (installation option K).

### 4.1 Special tools and equipment

No special tools or equipment are necessary to install, to connect or for commissioning.



**ATTENTION**

**Make sure that the correct equipment and tools are used.**

### 4.2 Mounting positions

- Refer to the illustrations and use only a permitted mounting position for installation!
- **After installation** interchange the plug in the highest position with the vent plug! This is **not** applicable to motor gearboxes that are filled with grease!

**RW45 [grease lubrication]:**

$315^\circ \leq \alpha \leq 180^\circ$  ✓  $180^\circ < \alpha < 315^\circ$  ✗

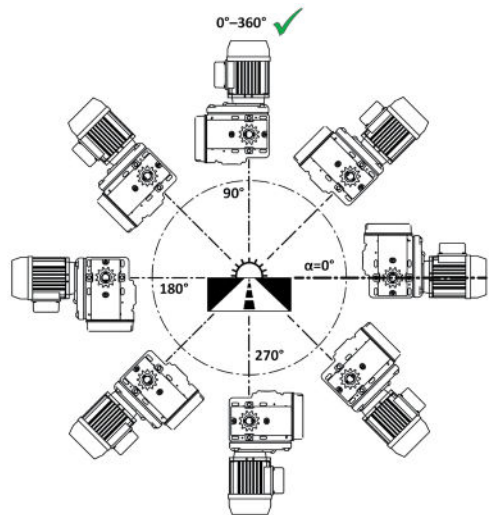
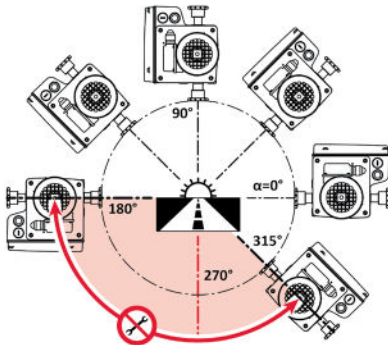



### RW240/400/600 [oil lubrication]:

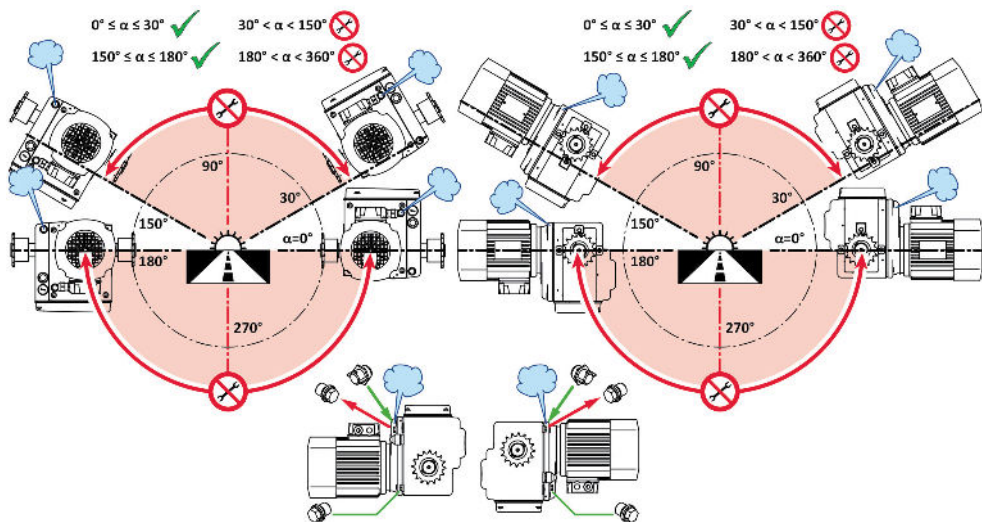

### RW240 [grease lubrication]:

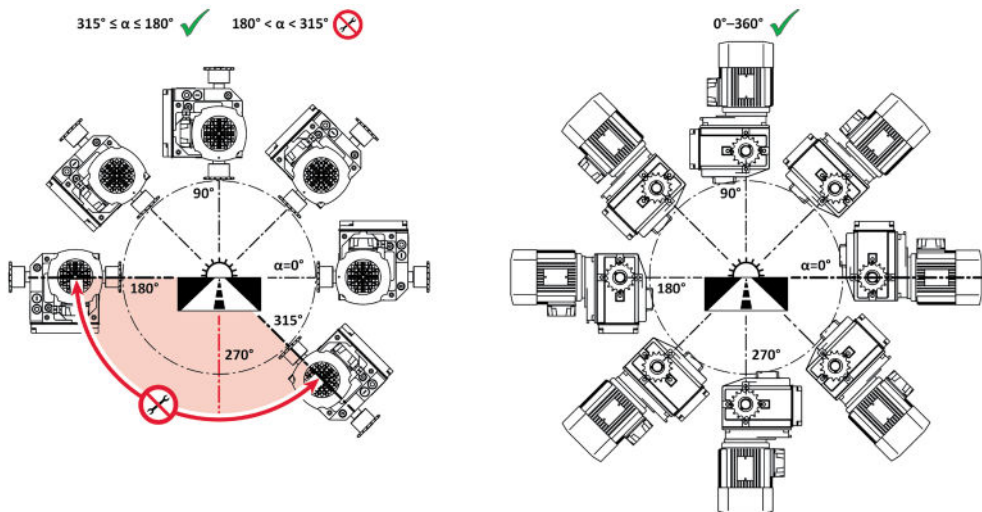



### RW800 [oil lubrication]:

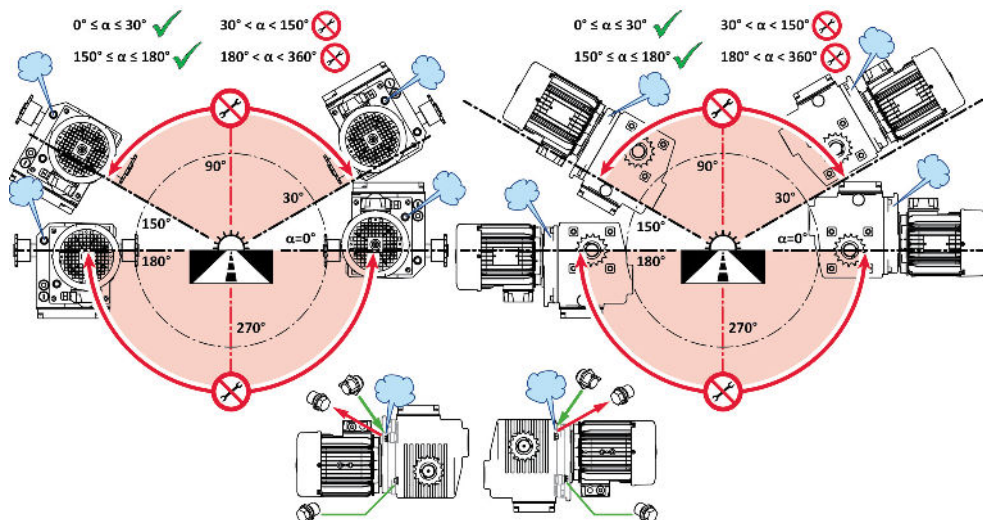

### RW70/140-34 [oil lubrication]:

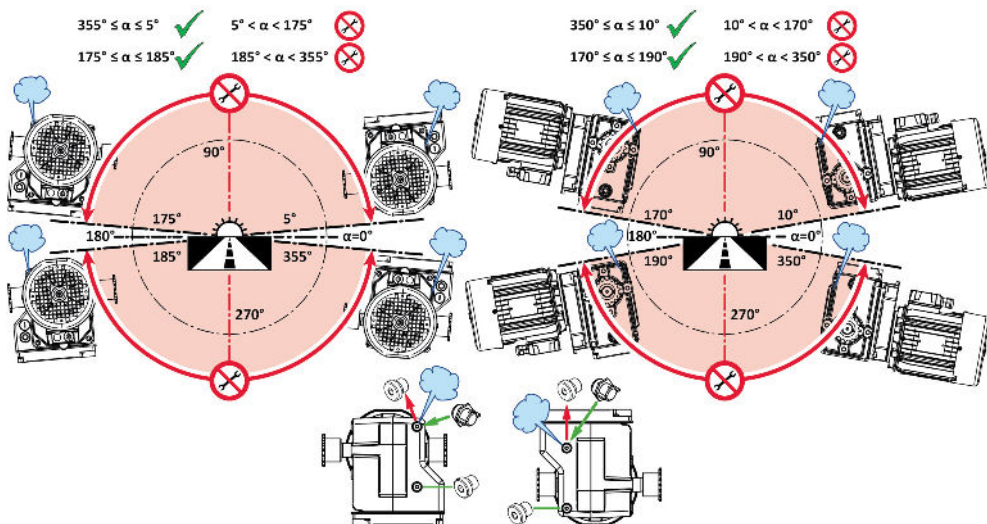

### 4.3 Sprockets

- **Usually** Ridder installs sprockets onto the **two basic output shafts (BOS)** of most models (general designation: RW).
- Some models (such as RW-LK, RW-D, RW-LD) have:
  - **One** special output-shaft (**LK**) plus **one** basic output shaft (**BOS**)
  - **One** special output-shaft (**D**) plus **two** basic output shafts (**BOS**)
  - **Two** special output-shafts (**L + D**). (The L-shaft is for installation of a drum.)
- Some models or shafts (BOS and/or special shafts) are supplied without sprockets.



Thus it is possibly necessary, if applicable for the configuration, to:

- 1 Install necessary (optional) sprockets on output shafts or
- 2 Interchange sprockets with necessary (optional) sprockets on output shafts.

Refer to the illustration (step 1 and 2) that follows for the configuration of shaft keys (a), b), retaining rings (c) and ring (d).

For more information on item numbers and models refer to the Ridder catalog or website at [ridder.com](http://ridder.com).

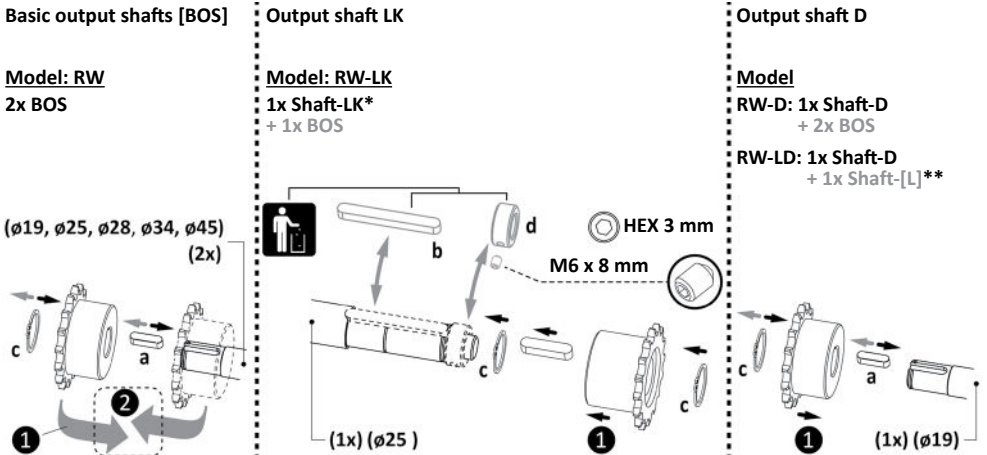

\* Shaft LK-model: Installation of a drum is also possible. Refer to §4.7/4.8.

\*\* Shaft L-model is for installation of a drum. Refer to §4.7/4.8.

## 4.4 Installation

---

The conditions and starting points that follow are applicable for installation. Make sure that the working conditions comply with the, local or national, laws and regulations.

- Do not remove the product from the packaging until a short time before the installation.
- Use the correct work equipment and accessories (belts, chains, pallets or such) if it is not permitted or possible to put the product manually in position.
- Only use a permitted mounting position when you install the RW motor-gearbox. Refer to §4.2.
- The mounting plates are available in different dimensions for different configurations. Refer to “Optional mounting plates ①”.

Install the RW motor-gearbox onto the mounting plate or an alternative (refer to “Optional mounting plates ②”):

- With the supplied spring washers and bolts M10x20 (2x) for an RW45 drive unit
- With the supplied spring washers and bolts M10x25 (3x) for RW240–600 and RW70/140 drive units
- With the supplied spring washers and bolts M12x25 (4x) for an RW800 drive unit.

Refer to “**Minimum Screw-in depth (SID)**” which also shows the **standard bolt-installation (SBI)**.

- The RSU or RLS limit-switch system and other components (RPU and such) can give information “in operation” and/or during commissioning. Thus, easy access and a satisfactory view is recommended for the location of the RW motor-gearbox.
- In the factory the reductor is filled with the necessary quantity of grease (usually only RW45) or oil. After installation interchange (of reductors filled with oil) the plug in the highest position with the vent plug! Refer to §4.2.

## Optional mounting plates

- 1 A. Mounting plates:** Do bolt attachment or welded attachment to a structure. Use wedge bolts (or such) for wall mounting.
- B. Mounting plates:** Do bolt attachment to a structure (different lattice heights possible).
- C. Clamp mounting plates:**
  - C1.** Use a base plate (#) and a type A mounting plate (\*) on C-profiles.
  - C2.** Do clamp mounting on posts.
  - C3.** Do clamp mounting on lattices (different lattice widths and lattice heights possible).

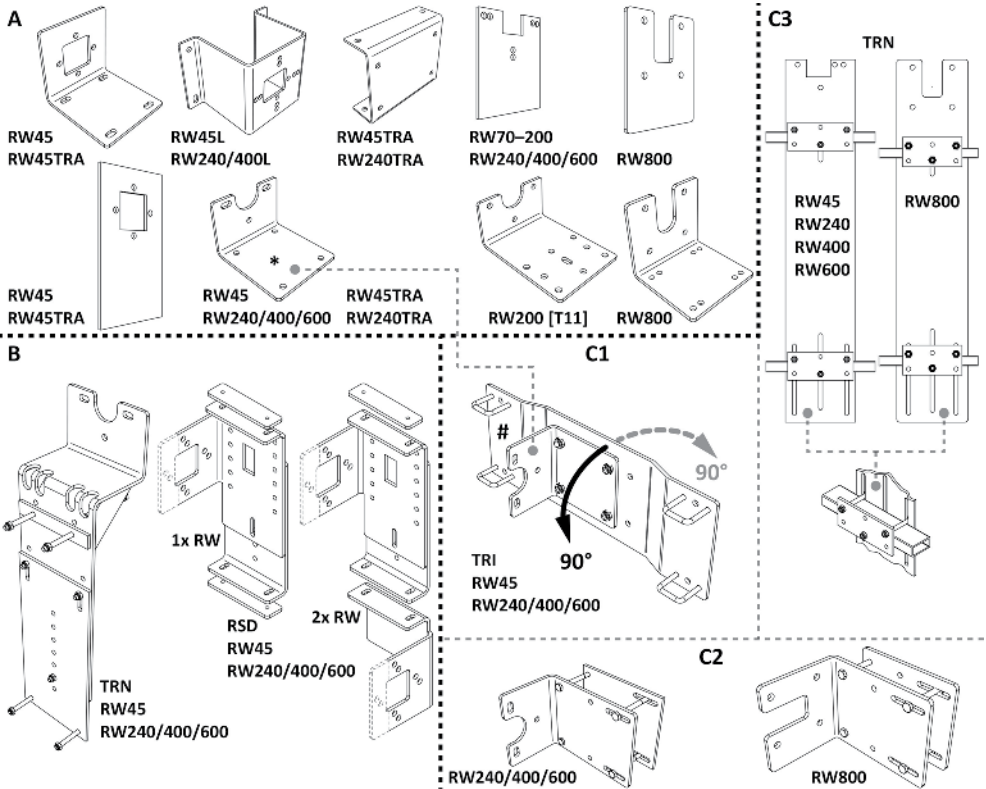

In this manual shown illustrations can be different than the components and/or systems. For more information on item numbers and models refer to the Ridder catalog or website at [ridder.com](http://ridder.com).

- 2 Do the **standard bolt-installation (SBI)** of the motor gearbox on the applicable mounting plate or an alternative.



Make sure that the drive unit is installed in a stable condition. The structure must have sufficient strength for the applied forces.



Make sure that easy access to the cover of the RW motor-gearbox is possible for all work.



Installation **OUTDOORS** of RW motor-gearboxes is only permitted with **PROTECTION** from RAIN (protection covers or such) at a minimum temperature of 0 °C. Problems with moisture and/or the IP protection rating (if applicable) must be prevented.

### Minimum Screw-in depth (SID)

- For the tightening torque of the used fixing bolts a **minimum screw-in depth (SID)** is necessary. Refer to the illustrations (Standard Bolt-Installations [SBI]) that follow.
- Possibly fixing bolts with more length are necessary if a larger sheet thickness is used!
- Tighten the bolts crosswise and gradually with the correct tightening torque (Nm).

### Standard Bolt-installations (SBI)

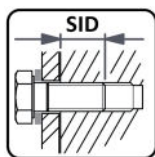

RW45-800

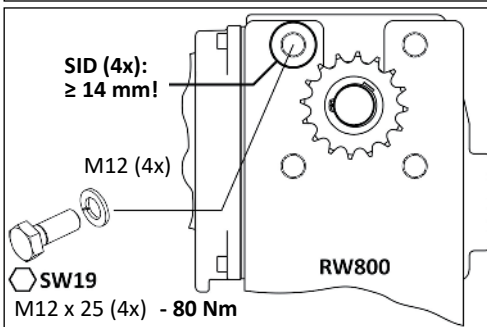
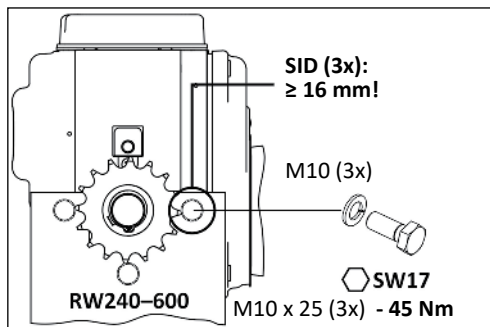
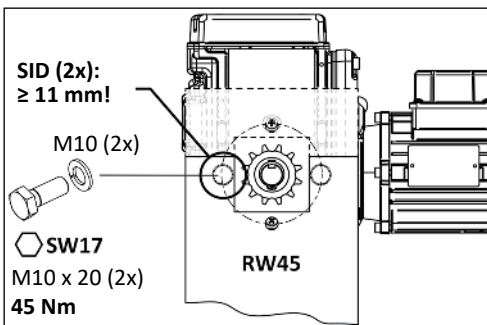

Ridder Drive Systems B.V.

T +31 (0)341 416 854 - F +31 (0)341 416 611 - I ridder.com

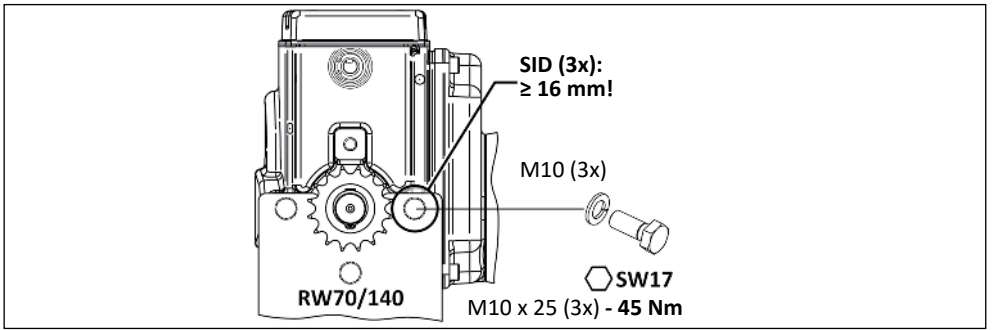

 **CAUTION**

Do the check of the minimum screw-in depth (SID) of the configuration that follows:  
SHEET THICKNESS and fixing-bolt LENGTH.  
This prevents damage or injury (breakage risk).

## 4.5 Installation options A–F for output shafts

### 4.5.1 Basic output shafts (BOS)

Installation options A–F show the (most) used connections (chain couplings/universal joints) of **basic output shafts (BOS)** to operated systems.

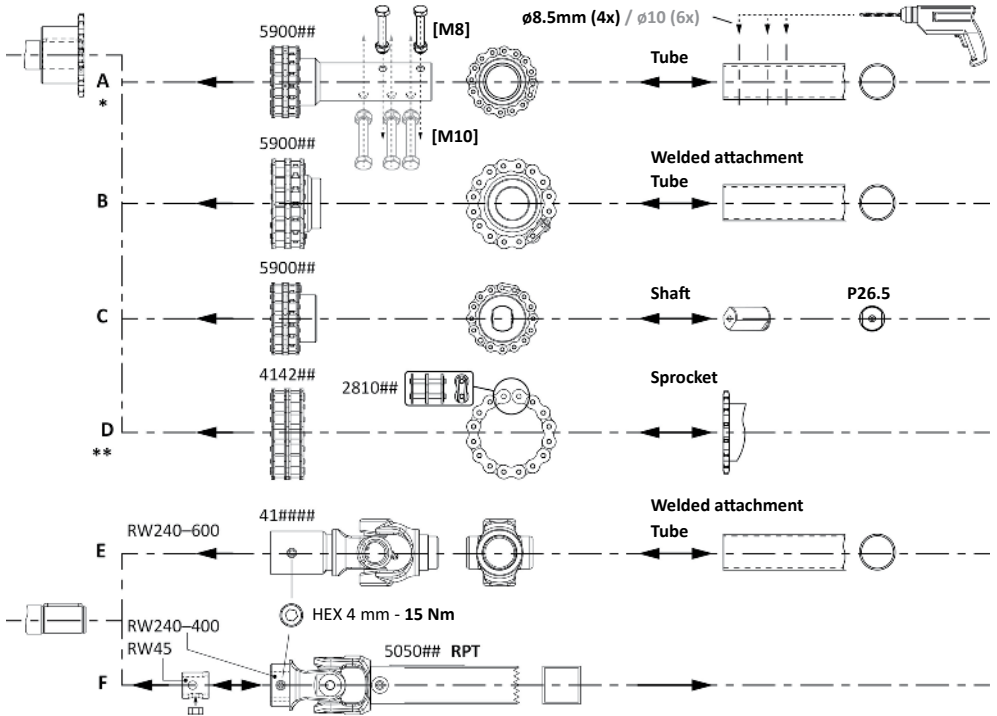

\* M8 and M10 bolts with lock nuts (and related tightening torque) are recommended for the applicable configuration.

\*\* D is supplied as two parts (chain, chain connector).

In this manual shown illustrations can be different than the components and/or systems. For more information on item numbers and models refer to the Ridder catalog or website at [ridder.com](http://ridder.com).

### 4.5.2 Special output-shafts (D, LD, LK ....)

Installation options A–F are (possibly) also applicable, if necessary for the operated system, for models such as **D, LD** or **LK** (or other designations).

**NOTE:** Make sure that the configuration, together with the operated system, agrees with §1.3 “Warning about discouraged use” and §3.3 “Application” (intended use). Possibly approval from Ridder Drive Systems is necessary.



**Ridder Drive Systems B.V.**

T +31 (0)341 416 854 - F +31 (0)341 416 611 - I [ridder.com](http://ridder.com)

### 4.5.3 Installation chain (for A-D)

This section shows, for installation options A-D (if applicable), the installation of **chains** onto sprockets.

#### Preparing components

- Remove the chain connector (2810##) from the (installed) chain (1-3).
- If installed, remove the chain from the sprocket of the chain coupling (4).

1-4 Remove the chain connector (and the chain from the sprocket).

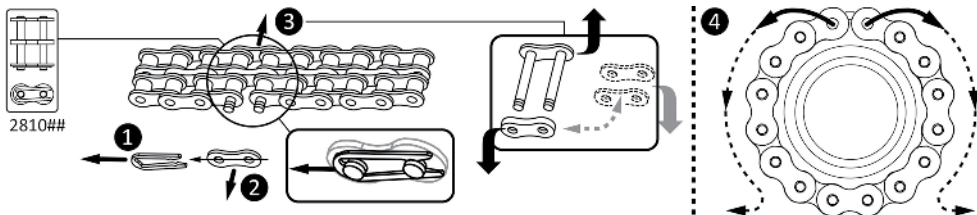

- 5 Turn the sprockets and make sure that the teeth are aligned.
- 6 Put the chain onto the sprockets with the chain ends at the top.

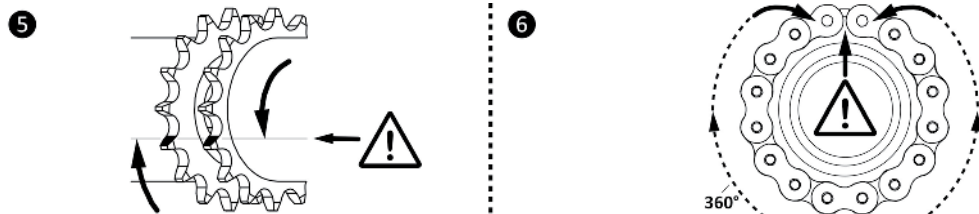

#### Install the chain

1-8 Install the chain connector and chain (on the sprockets).

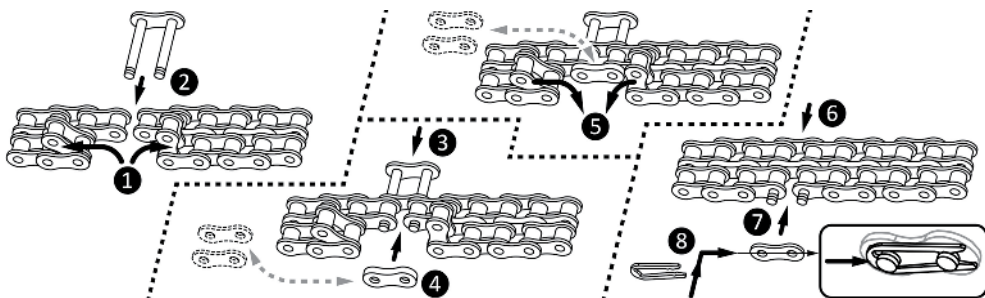



### Installation options G, H, I

**G:** Type A mounting plate installed between the motor gearbox and the TRA drive-unit.

Refer to §4.4: "Optional mounting plates", step ① A.

Do the steps ①, ② + ③, ④, ⑤ of the **two illustrations** that follow.

**H:** Foot mounting or top mounting of the on the motor gearbox installed TRA drive-unit.

Do the steps ①, ② + ④, ⑤ + ⑥ or ⑦ of the **two illustrations** that follow.

**I:** Wall mounting with the special wall mounting plate (417910/417953) of the on the motor gearbox installed TRA drive-unit.

Do the steps ①, ② + ④, ⑤, ⑧, ⑨ of the **two illustrations** that follow.

### Preparing components (G, H and I)

① Install the shaft key (d), the pinion (e) and the retaining ring (f) onto the output shaft.

② Put the rack (g) through the TRA rack drive-unit.

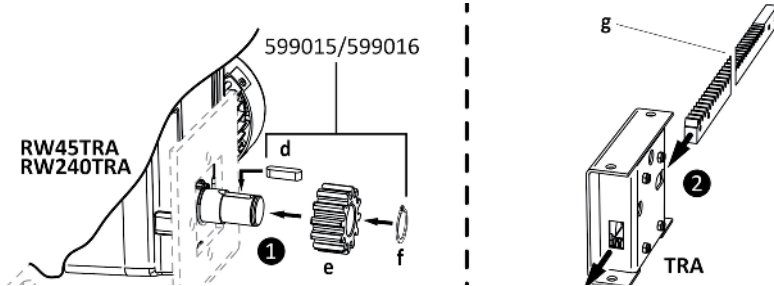

### Installation option G

**Note:** Possibly there is no mounting plate installed to the structure at this time. Install a (type A) mounting plate or an alternative to the structure first.

Refer to §4.4: "Optional mounting plates", step ① A.

- ③ Put the (type A) mounting plate (h) or an alternative between the gearbox and the TRA drive-unit.
- ④ Install the TRA rack drive-unit onto the gearbox (and mounting plate or alternative [h]) with the special M10 bolts ([i] 599015/599016).
- ⑤ Tighten the bolts (i) gradually with the correct tightening torque. Refer to **SID/SBI** information.

### Installation option H

- ④ Install the TRA rack drive-unit onto the gearbox with the special M10 bolts ([i] 599015/599016).
- ⑤ Tighten the bolts (i) gradually with the correct tightening torque. Refer to **SID/SBI** information.
- ⑥/⑦ Drill two holes of  $\varnothing 13\text{mm}$  for foot mounting (j) or top mounting (k) in the structure. Use M12 fasteners (l or m) to install the TRA system onto the structure. Obey the instructions for installation of M12 fasteners (l or m).

### Installation option I

- 4 Install the TRA rack drive-unit onto the gearbox with the special M10 bolts ([i] 599015/599016).
- 5 Tighten the bolts (i) gradually with the correct tightening torque. Refer to **SID/SBI** information.
- 8 Install the wall mounting plate (n) onto the wall. Use four M10 fasteners ([o] wedge bolts or such) for the wall mounting. Obey the instructions for installation of M10 fasteners ([o] wedge bolts or such).
- 9 Install the TRA drive-unit to the wall mounting plate (n) with four M10 bolts (p) and lock nuts. Obey the instructions for installation of M10 fasteners (p).

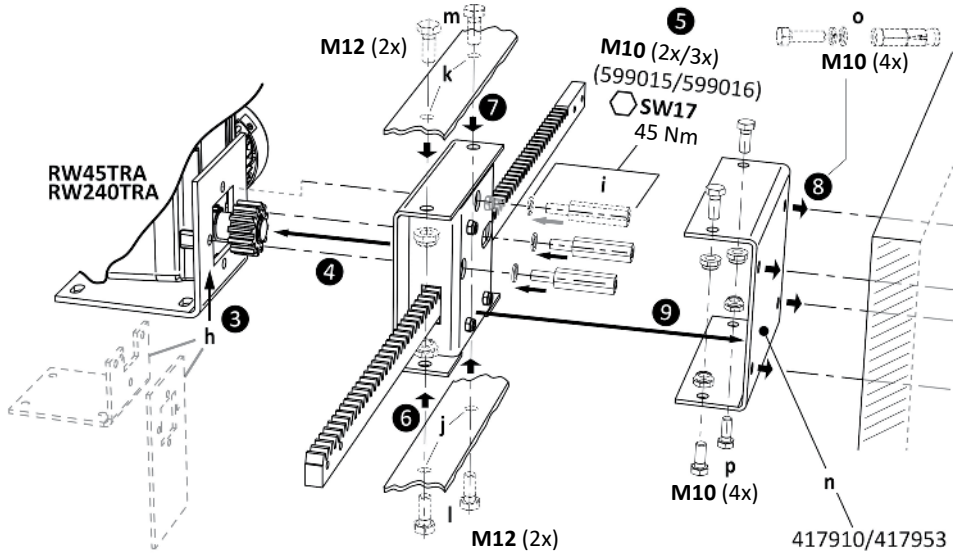

The TRA520 rack-drives have zinc-plated racks with different lengths. Attach the racks to coupling-plates, push-pull tubes, steel cables and/or such.

In this product manual shown illustrations can be different than the components and/or systems. For more information on item numbers and models refer to the Ridder catalog or website at [ridder.com](http://ridder.com).

## 4.7 Belt drum onto RW45\240/400L motor gearbox

### Installation option J

Install the drum and belt (one or two [with triangle for example]) onto the RW45L or RW240/400L drive unit. Refer to the illustration that follows.

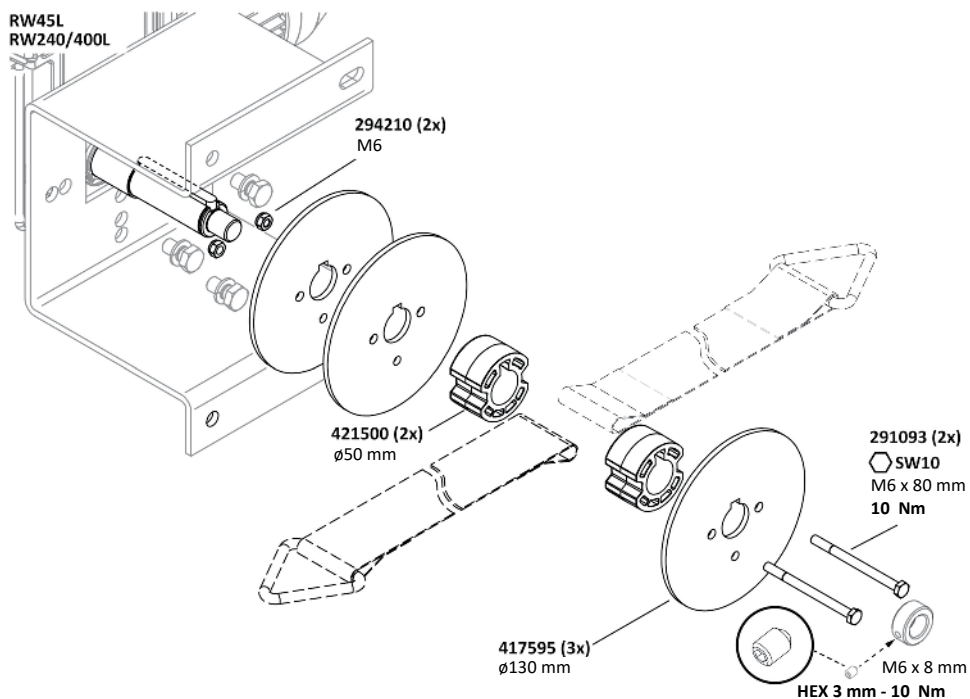

In this manual shown illustrations can be different than the components and/or systems. For more information on item numbers and models refer to the Ridder catalog or website at [ridder.com](http://ridder.com).

## 4.8 Cable drum onto RW45\240/400L motor gearbox

### Installation option K

Install the drum and cable (one or two) onto the RW45L or RW240/400L drive-unit. Refer to the illustration that follows.

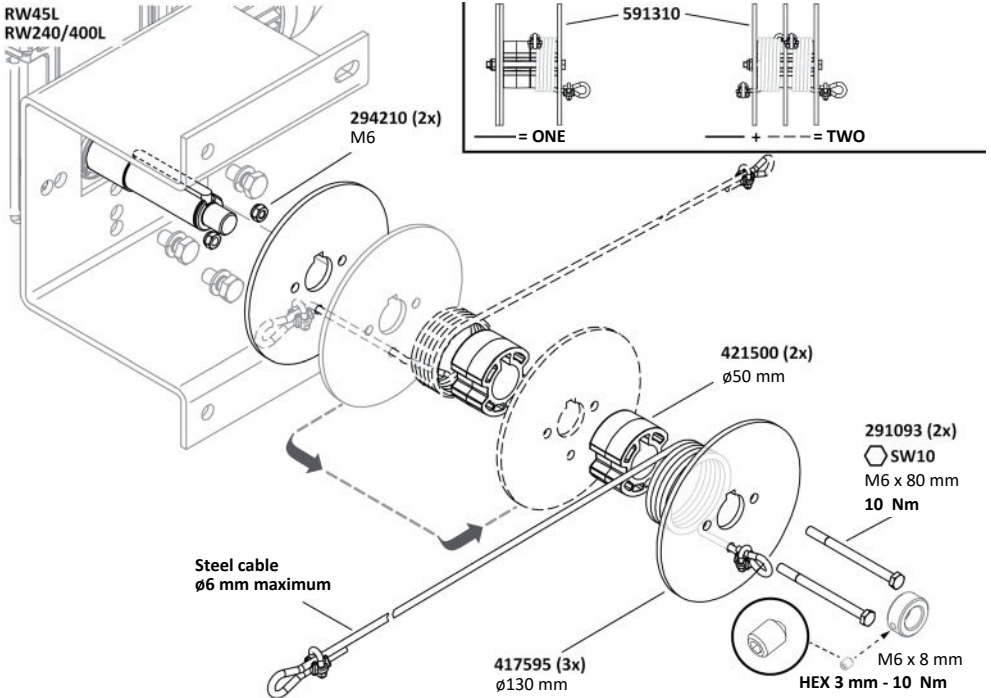

In this manual shown illustrations can be different than the components and/or systems. For more information on item numbers and models refer to the Ridder catalog or website at [ridder.com](http://ridder.com).

**Note:** Ridder does not supply steel cables and steel cable clamps.

## 5. CONNECT INSTRUCTIONS

Only to approved personnel it is permitted to do the connect instructions.

The RW motor gearboxes are applicable for use in an industrial environment where electromagnetic interference can have an effect. Usually correct installation makes sure that functional operation is safely possible without problems. Make sure that the connections obey EMC-conformity.

- When you put the cables, make sure that **water flows away** from the motor gearbox (make loops if necessary). Refer to §5.2 "Cable glands".
- Make sure that during connection work all phases of all power connections (power supply) are **de-energized**.



The power supply of the motor gearbox can directly or not directly put the drive unit into movement. This can also cause an electric shock which can kill you if electrical components are touched.

### Mains-voltage loop-connection

If a mains-voltage loop-connection is used, make sure that connection terminals, plug connectors and cables are sufficient for the permitted current load. If you do not obey this instruction thermal damage to components or adjacent objects can occur.

### 5.1 Removal covers

- Remove the bolts (2x4 [or 1x4 + 1x3]) and the covers (2x) temporarily to do all necessary work. The gaskets (2x) usually stay in their position.
- Make sure that no damage is caused to the gaskets and that they do not become dirty.
- Install the covers (2x) again after the work! Refer to the end of chapter 7.

#### Plastic cover \*

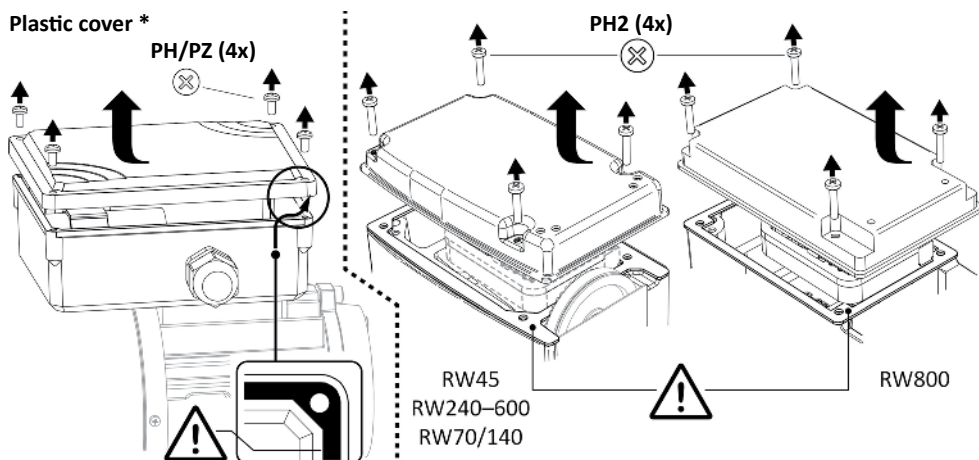

#### \* Alternatives: Metal cover

##### TX\SLOT (3x)

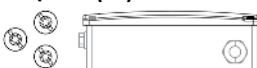

##### PH/(PZ) (4x)

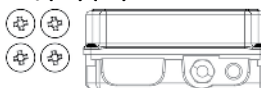

In this manual shown illustrations can be different than the components and/or systems.



Ridder Drive Systems B.V.

T +31 (0)341 416 854 - F +31 (0)341 416 611 - I ridder.com

## 5.2 Electrical material

---

- A minimum conductor cross-section of 1.5 mm<sup>2</sup> is applicable to the cables in the general wiring diagrams. For the used components, electrical material and cable lengths the necessary conductor cross-section can be different.



**Use only applicable components and electrical material.  
Always refer to the related information and manuals.**

### **RW243/245/400/600\RW800\RW70/140 [RSU]**

- Motor-current connection through the RSU limit-switch system is **not permitted!**

The limit-switch system is applicable for the currents that follow:

- **45 mA–130 mA** at 24 V AC/DC
- A **maximum of 100 mA** at 115/230/240 V.



**The RSU limit-switch system is NOT applicable for motor-current connection through the limit switches.**

### **RW45\RW241/242 [RLS]**

- Motor-current connection or control-circuit connection through the RLS limit-switch is **permitted.**

The limit-switch system is applicable for the currents that follow:

- **45 mA–130 mA** at 24 V AC/DC
- A **maximum of 4 A** at 115 V
- A **maximum of 2.25 A** at 230/240 V.

## Cable glands

The RW motor-gearbox has (installed) cable glands M20x1.5 mm and/or M16x1.5 mm to put through the motor connections (EM) and the limit-switch cables (RLS/RSU).

The conditions and starting points that follow are applicable:

- Always put only **one cable** through **one cable gland**.
- Use a cable with a conductor-diameter of **Ø6.0–12.0 mm** and a tightening torque of **5.0 Nm** for cable glands **M20x1.5 mm**.  
Use a cable with a conductor-diameter of **Ø5.0–10.0 mm** and a tightening torque of **2.5 Nm** for cable glands **M16x1.5 mm**.
- Make sure that water **flows away** from the cable glands (cable routing: make loops if necessary).



**Make sure that all openings are correctly sealed with cable glands or with initially installed blind plugs. This prevents problems with moisture and/or the IP protection rating.**

Obey the procedure that follows:

- 1 Loosen the cable gland.
- 2 Remove the sealing plug\*.
- 3 Put the cable through the cable gland.
- 4 Tighten the cable glands with the correct tool and tightening torque.



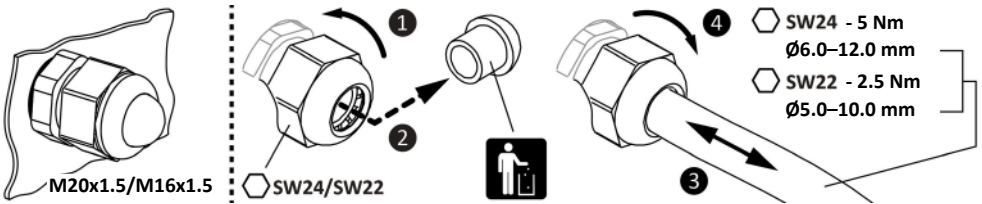





\* If your decision is not to use this cable gland, make sure to put the sealing plug back. Tighten the cable gland with the correct tool and tightening torque!



### 5.3 Protection - Conditions and starting points

The conditions that follow are applicable to the wiring diagrams.

- The installer makes sure that necessary and not shown protections are used and included in the wiring diagrams.
- Make sure that you can see the operated system from all control units and control systems. Put control units and control systems at a height that agrees with applicable standards and guidelines.
- Protect the electric connections from moist conditions.
- Obey the applicable standards, guidelines and/or wiring guidelines for electrical connections.

 <b>WARNING</b>	<b>Electrical connections are only permitted to an electrical installer or an electrician.</b>
 <b>WARNING</b>	<b>A fully and correctly connected wiring diagram is necessary. It is mandatory to connect all safety switches and duty switches.</b>
 <b>WARNING</b>	<b>ELECTRIC SHOCK</b> <b>There can be dangerous voltages, also when the drive unit is not in operation.</b>
 <b>CAUTION</b>	<b>For installation work, connection work and maintenance work the system must be de-energized.</b>
 <b>CAUTION</b>	<b>Make sure that each electric motor (EM) is stopped (only) with its own limit-switch system. This prevents the risk of incorrect control, an incorrect direction-of-rotation or incorrect operation of limit-switch systems of different electric motors.</b>
 <b>CAUTION</b>	<b>The waiting time must be approximately 2 seconds when you change the direction-of-rotation. The electric motor must stop. This prevents that it continues in the initial direction.</b>
 <b>ATTENTION</b>	<b>The installer sets the Motor-Protection Circuit-Breaker (MPCB[Q41]) to the value of the nominal current of the electric motor.</b>
 <b>ATTENTION</b>	<b>Always make sure that the protections comply with the, local or national, laws and regulations of the country.</b>



## EMC Interference

Problems with electromagnetic interference must be prevented. For a correct functional operation possibly precautions, such as an EMC mains-filter, are necessary.

 <b>ATTENTION</b>	<b>It is necessary to obey EMC-conformity. This prevents problems with electromagnetic interference.</b>
--	--

## Induction

Problems with induction must be prevented. Induction can cause an interference with the electronics.

Induction can have many causes such as:

- Cable lengths
- External sources
- Too many cables together.

 <b>ATTENTION</b>	<b>Separation of cables is necessary. This prevents problems with induction.</b>
--	--

## 5.4 Tightening-torque motor-connections

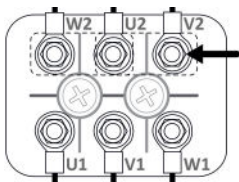

⬡ SW7\M4  
2 Nm!  
(6x)

⬡ SW8\M5  
3 Nm!

Tighten the motor connections with the correct tightening torque!

- **M4 connections: 2 Nm**
- **M5 connections: 3 Nm.**

## 5.5 Control-circuit connection - 3-wire [RLS]

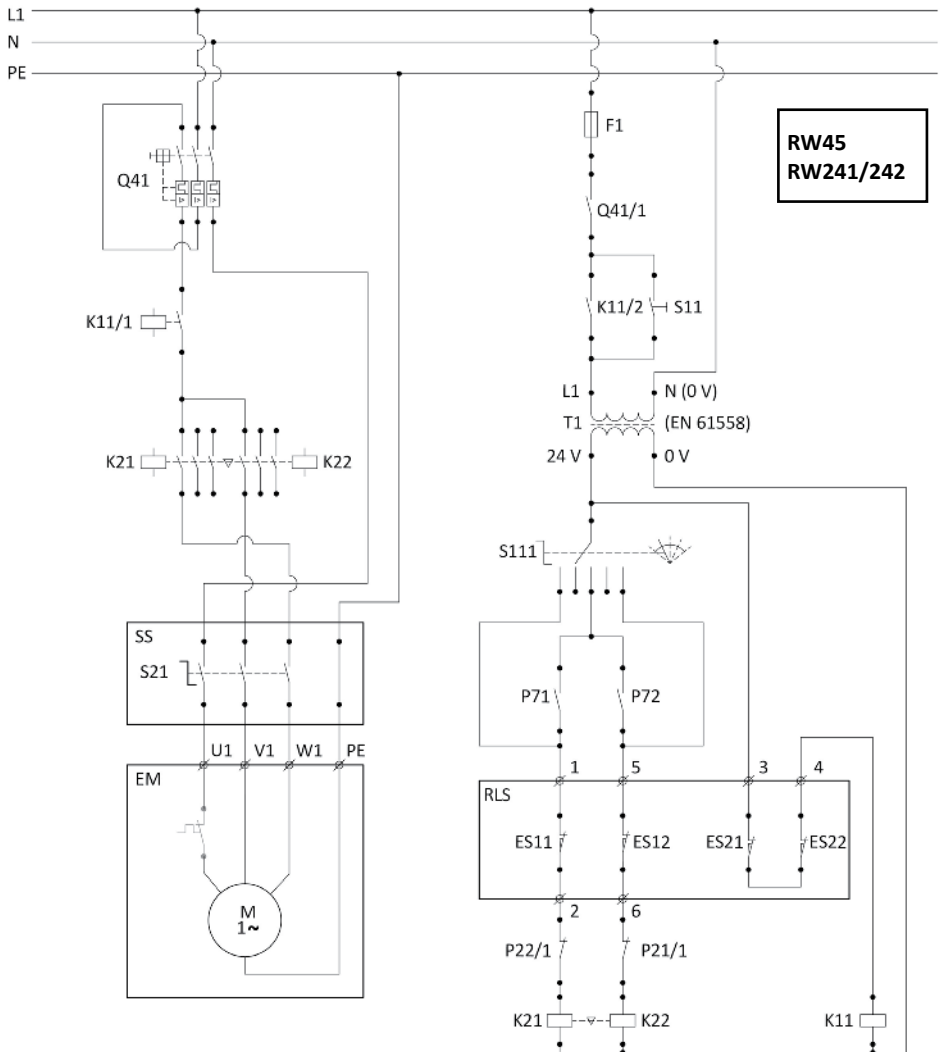

**RW45  
RW241/242**



**WARNING**

**Connect all safety switches (ES21/22) and duty switches (ES11/12).  
This is necessary for safety and correct functional operation.**

**RLS connections: 1–6**

5.6 Motor-current connection - 3-wire [RLS]

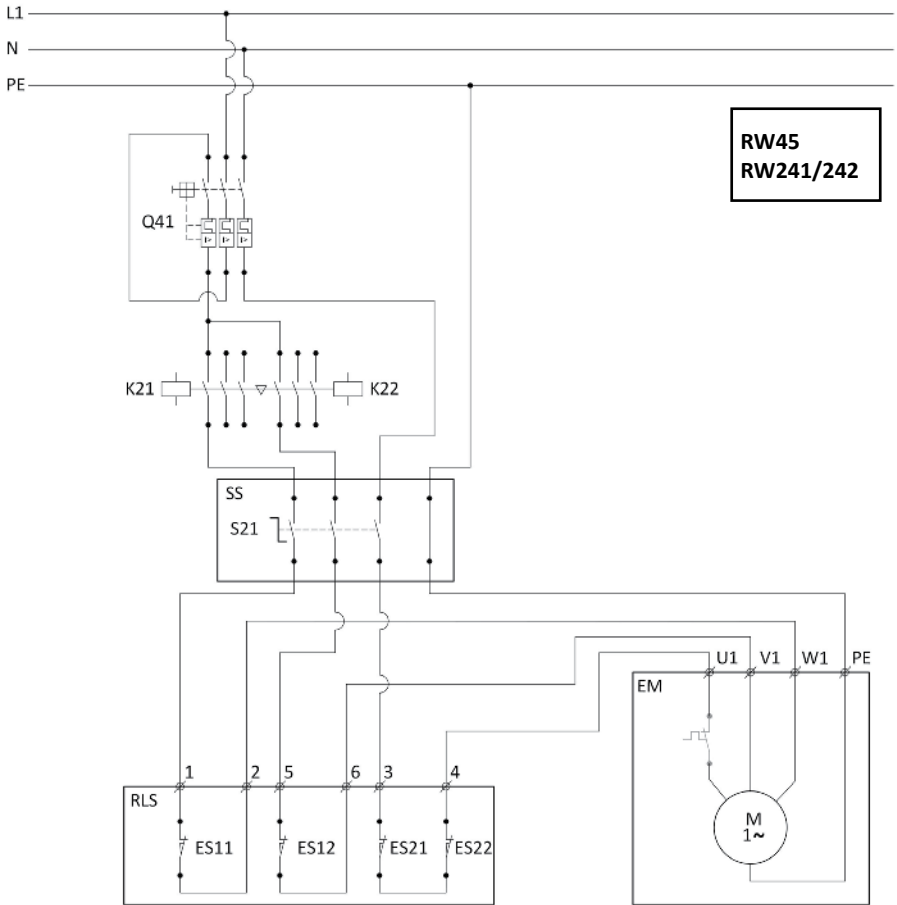

**! WARNING**

Connect all safety switches (ES21/22) and duty switches (ES11/12). This is necessary for safety and correct functional operation.  
RLS connections: 1–6

**! CAUTION**

Do NOT connect 1-phase electric motors (EM), that have motor-current connection through the RLS limit-switch system, in PARALLEL. This prevents the risk of incorrect control, an incorrect direction-of-rotation or incorrect operation of limit-switch systems of different electric motors.



## 5.7 Control-circuit connection - 5-wire [RSU]

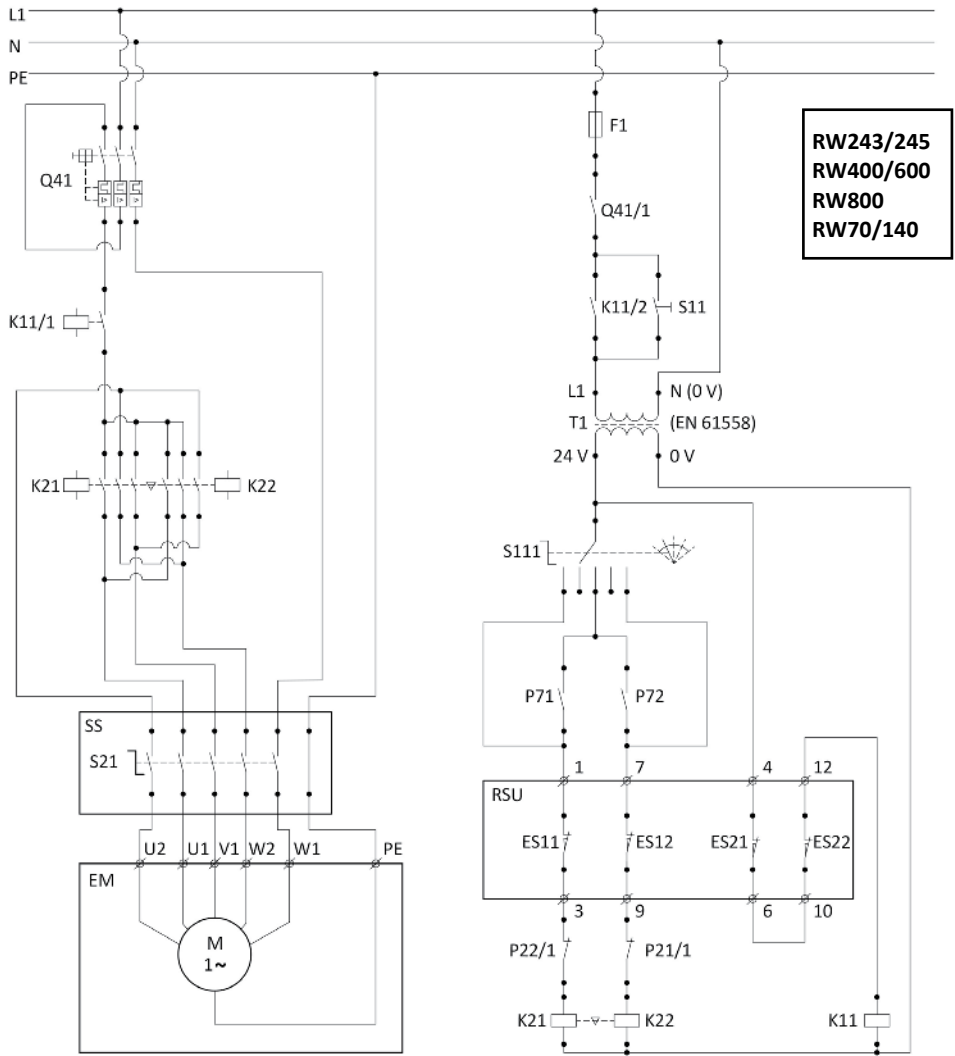

**WARNING**

Connect all safety switches (ES21/22) and duty switches (ES11/12).  
 This is necessary for safety and correct functional operation.  
 RSU connections: 1–12

## 5.8 Control-circuit connection - 5-wire, Alternative [RSU]

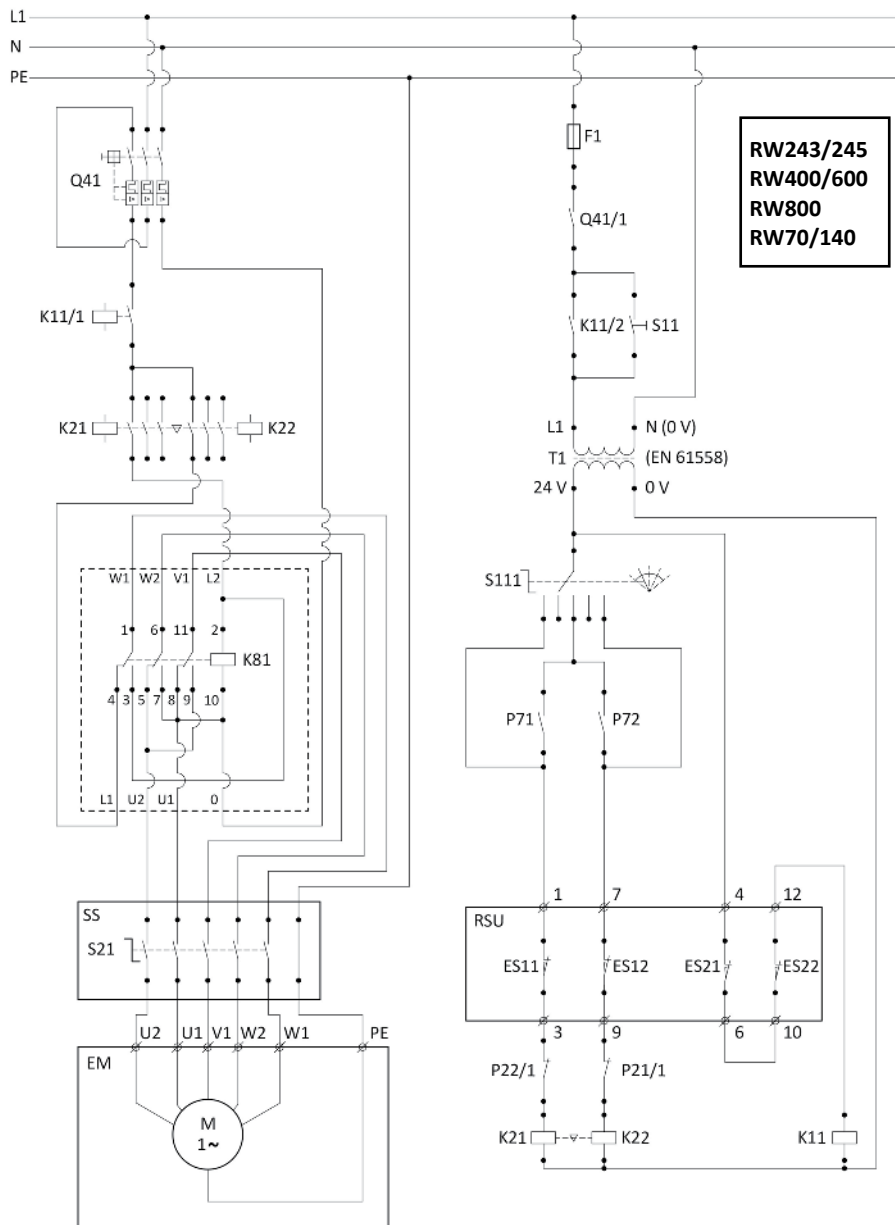

**RW243/245  
RW400/600  
RW800  
RW70/140**



**WARNING**

**Connect all safety switches (ES21/22) and duty switches (ES11/12).  
This is necessary for safety and correct functional operation.  
RSU connections: 1–12**



**Ridder Drive Systems B.V.**

**T +31 (0)341 416 854 - F +31 (0)341 416 611 - I ridder.com**

## 5.9 Change Direction-of-rotation - Switching sense

---

If necessary, it is possible to change the direction-of-rotation and/or the switching sense. Refer to §6.2, §7.2 and §7.3.

### Wiring diagram §5.5–5.6 [RLS]: RW45\RW241/242



**TIP**

**Change direction-of-rotation:**

Interchange V1 and W1 on the terminal block (EM).

**Change switching sense:**

Interchange 1 and 5 of the RLS.

### Wiring diagram §5.7–5.8 [RSU]: RW243/245/400/600\RW800\RW70/140



**TIP**

**Change direction-of-rotation:**

Interchange V1 and W2 on the terminal block (EM).

**Change switching sense:**

Interchange 1 and 7 of the RSU.

## 5.10 OPTIONAL - Position Feedback

---

You can connect a digital positioning-meter (**RPU**) or a Ridder **Potentiometer** installation set to the RW motor-gearbox. Refer to the product-manuals at [ridder.com](http://ridder.com) for the installation and connections.

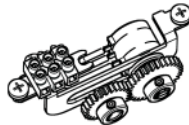
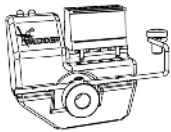

## 6. USER INSTRUCTIONS

---

If work becomes necessary when you use the drive unit (normal operation), **approved personnel** usually must do the work.

### 6.1 Usage - Conditions and starting points

---

The conditions and starting points that follow are applicable when you use the RW motor-gearbox.

#### Automatic Control



**DANGER**

**The motor can start and stop automatically without a warning. Persons can be in danger of life if they touch a system that is in operation.**

### Thermal protection/Temperature

3-wire electric motors are thermally protected with a built-in PTO switch. If the motor temperature becomes higher than 140 °C the system stops. When the motor temperature decreases to less than 140 °C the system automatically starts again.



The motor can start and stop automatically without a warning but will stay energized. De-energize the system during work on the drive unit or the system. Persons can be in danger of life if they touch a system that is in operation.



A drive unit can get high temperatures. If necessary take protective precautions to prevent injuries.

### Waiting time



The waiting time must be approximately 2 seconds when you change the direction-of-rotation. The electric motor must stop. This prevents that it continues in the initial direction.

### SAFETY STOP



When a “safety stop” (safety switch) occurs:

- Do a check of the condition of the operated system.  
Make sure that the system can be safely operated.
- Do a check of the condition of the limit-switch system (adjusting screw --> switching spring).  
Make sure that the system can be safely operated.
- If necessary:  
Adjust the end positions again.  
This prevents damage or injury.

## 6.2 Direction-of-rotation RW motor-gearboxes

The illustrations that follow show the motor gearboxes with the related directions-of-rotation A and B. The limit switches A and B of the **RLS/RSU** are also shown.

**Direction-of-rotation A = Limit switch A = ES11/ES21 - Refer to §7.2**

**Direction-of-rotation B = Limit switch B = ES12/ES22 - Refer to §7.2**

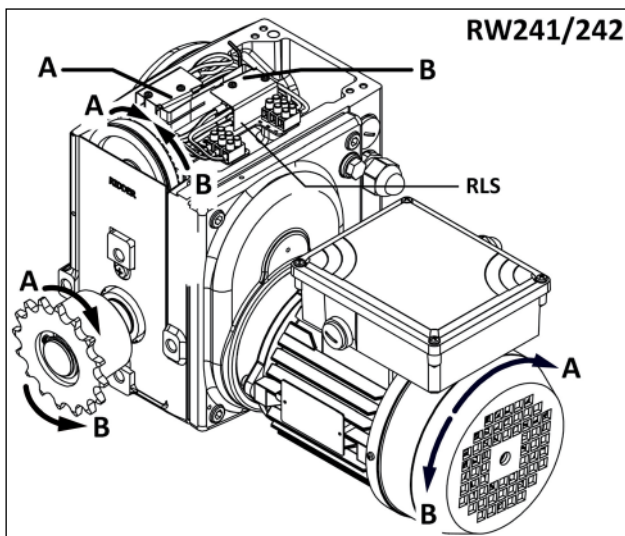
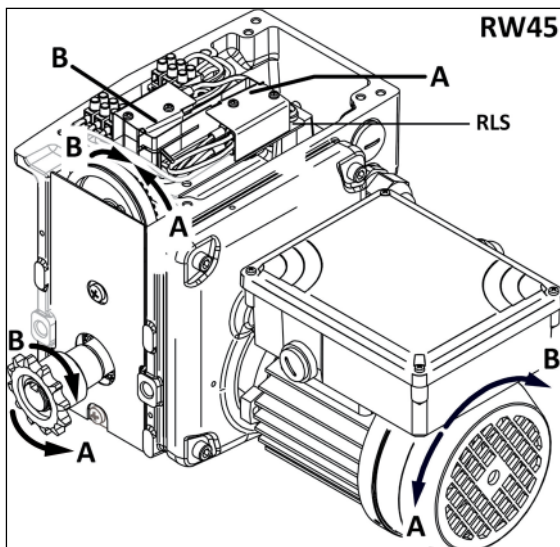



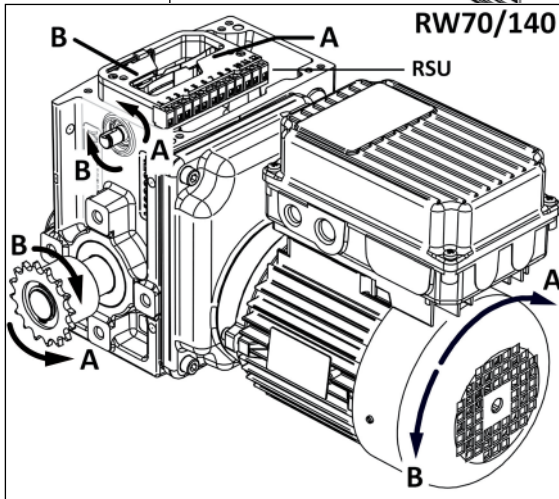
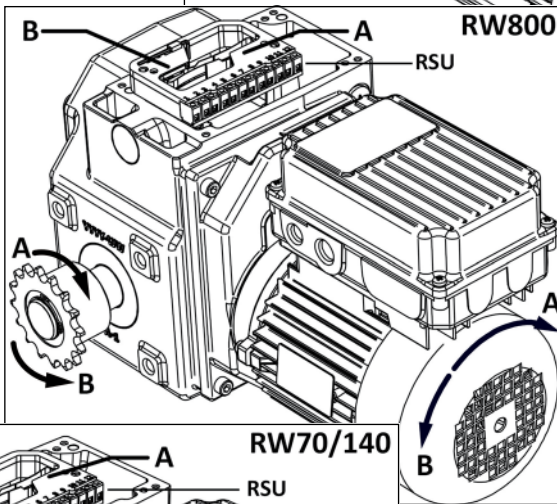
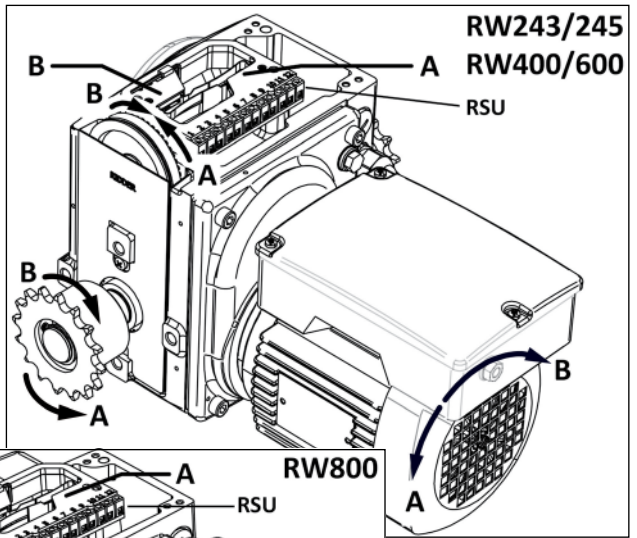

Ridder Drive Systems B.V.

T +31 (0)341 416 854 - F +31 (0)341 416 611 - I [ridder.com](http://ridder.com)

## 6.3 Operation

---

The RW motor-gearboxes are usually used in automated systems.

Operation is possible with a manual control (MC) and/or other Ridder control components, which are compatible with (if applicable) "Automatic Control-Systems" (ACS).

Refer to the Ridder catalog or website [ridder.com](http://ridder.com) for more information. Always refer to the related information and manuals (ACS and control components).

## 6.4 Safety functions and stop functions

---

The RW motor-gearbox has the safety functions and stop functions that follow:

1. Stop at an adjusted end position when a duty switch is operated
2. Stop when a safety switch is operated if a duty switch not disconnects
3. Stop when not operated and then lock the output shaft because of a self-braking worm-gear transmission
4. Thermal-overload protection of the electric motor with a built-in PTO switch.

## 7. COMMISSIONING INSTRUCTIONS

---

The commissioning is only permitted to approved personnel.

### 7.1 Commissioning - Conditions and starting points

---

- It is important to fully know the working principle of the RLS/RSU limit-switch system in §7.2.
- After that obey the procedure in §7.3.



**Do not go across the limits of the system. This prevents damage or injury.**



**Before the system is put into operation, the installer must always make sure that the limit switch is correctly adjusted.**



**Make sure that there is no blockage of the system before the limit-switch system is adjusted. This prevents damage or injury.**

## 7.2 RLS/RSU limit-switch system

The RLS/RSU limit-switch system is a linear switch-system. The output shaft of the motor gearbox operates the limit-switch system through a transmission. The number of revolutions of the output shaft can be set between the end positions.

### RLS: RW45\RW241/242

1. THREADED SHAFT
  2. KNURLED NUT
  3. ADJUSTING RING
  4. CONNECTION NUT
  5. SWITCHING SPRING
  6. STOPPER
  7. HEX WRENCH 2 MM
  - a. ADJUSTING SCREW  
LENGTH: 16 MM
  - b. ADJUSTING SCREW  
LENGTH: 6 MM
  8. SPARE PARTS a, b
- ES11/ES12  
DUTY SWITCH  
ES21/ES22  
SAFETY SWITCH

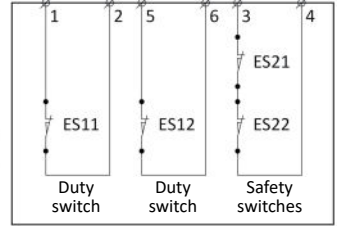
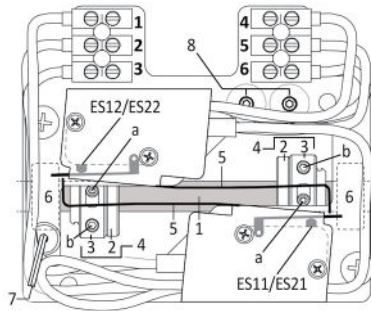

The switching range is 55, 86 or 97 revolutions of the drive shaft.

### RSU: RW243/245/400/600\RW800\RW70/140

1. THREADED SHAFT
  2. KNURLED NUT
  3. ADJUSTING RING
  4. CONNECTION NUT
  5. SWITCHING SPRING
  6. STOPPER
  7. HEX WRENCH 2 MM
  - a. ADJUSTING SCREW  
LENGTH: 16 MM
  - b. ADJUSTING SCREW  
LENGTH: 6 MM
  8. SPARE PARTS a, b
- ES11/ES12  
DUTY SWITCH  
ES21/ES22  
SAFETY SWITCH

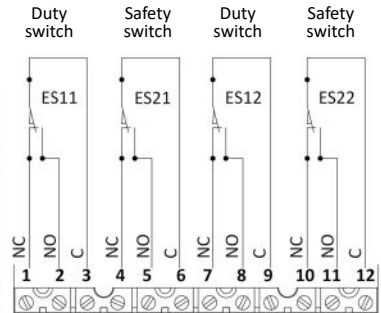
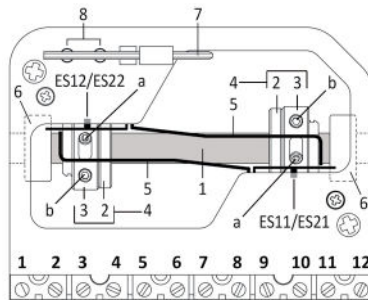

The switching range is 86, 120 or 860 revolutions of the drive shaft.

### RLS/RSU

An RW motor-gearbox has a limit-switch system with connection nuts (4). Ridder does **not lock** the adjusting rings (3). The drive unit can turn freely (temporarily, until the end positions are adjusted) in the two directions. This **prevents damage** to the limit-switch system (before it is electrical connected) when the motor is manually operated or is operated with electric tools!



**Do not go across the limits of the system when the motor is operated manually or is operated with electric tools (with the hexagon socket in the electric-motor shaft). This prevents damage or injury.**

## RLS/RSU CONTROL-CIRCUIT CONNECTION:

### Current (I) in the control circuit

The limit-switch system is applicable for the currents that follow:

- **45 mA–130 mA** at 24 V AC/DC
- A **maximum of 100 mA** at 115/230/240 V.

## RW45 - RLS MOTOR-CURRENT CONNECTION:

### Switching capacity of the limit switch at 115/230/240 V AC

A motor-gearbox with a 1-phase electric motor of:

- Maximum 0.09 kW at 115 V AC - 60 Hz or 230 V AC - 50 Hz
- Maximum 0.11 kW at 240 V AC - 60 Hz.

## RW241/242 - RLS MOTOR-CURRENT CONNECTION:

### Switching capacity of the limit switch at 115/230/240 V AC

A motor-gearbox with a 1-phase electric motor of:

- Maximum 0.18 kW at 115 V AC - 60 Hz or 230 V AC - 50 Hz
- Maximum 0.22 kW at 240 V AC - 60 Hz.

## CONNECTIONS AND FUNCTIONAL OPERATION

The **RLS** limit-switch system has two connection blocks. **Each** connection block has **three** connection terminals. The **RSU** limit-switch system has a connection block with **twelve** connection terminals.

- Starting point for a correct connection and functional operation is the wiring diagram in §5.5/§5.6 (RLS) or §5.7/§5.8 (RSU).
- Connection of all safety switches and duty switches is **mandatory**.

## WORKING PRINCIPLE

- The gearbox operates the threaded shaft (1) of the limit-switch system through a transmission.
- The connection nuts (4) move linearly along the threaded shaft (1).
- One adjusting screw (a) touches the switching spring (5).
- When a connection nut (4) is at the end position, it touches the stopper (6) and subsequently will turn with the threaded shaft (1).
- The adjusting screw (a) moves the switching spring (5) which operates the duty switch (ES11 or ES12). The motor gearbox stops.
- If a failure of the duty switch occurs, the switching spring (5) operates the safety switch (ES21 or ES22). This makes sure the motor gearbox stops. It prevents consequential damage to the system.



**Ridder Drive Systems B.V.**

**T** +31 (0)341 416 854 - **F** +31 (0)341 416 611 - **I** [ridder.com](http://ridder.com)

## 7.3 Adjusting the end positions

The conditions and starting points that follow are applicable:

- The direction-of-rotation of the motor gearbox is correct after connection in §5.5–§5.8.
- The switching sense of the RLS/RSU is correct after connection in §5.5–§5.8.
- Adjusting sequence: You can adjust the end positions from A to B or from B to A.

**Note:** Refer to §5.9 “Change Direction-of-rotation - Switching sense”.

### ► Description

Refer also to §6.2 “Direction-of-rotation RW motor-gearboxes” for the steps that follow.

1. Let the motor gearbox turn in the direction A or B.
2. Do a check to see which duty switch (ES11 or ES12) is related to direction A or B.
3. Let the system stop at an end position (A or B).



**Do not go across the limits of the system. This prevents damage or injury.**

Of the related limit switch (A or B):

- 2 1. Turn the knurled nut (2), on the threaded shaft (1), in the direction of the stopper (6).
2. Tighten the knurled nut (2) with your hand against the stopper (6).

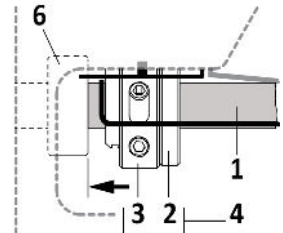

- 3 1. Turn the adjusting ring (3) in the opposite direction of the knurled nut (2). The adjusting screw (a) and switching spring (5) must operate the duty switch ES (ES11 or ES12).
2. Hold the adjusting ring (3) at this position and go to step 4.

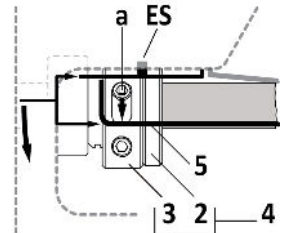

To lock the adjusting ring (3) on the knurled nut (2) with the **hex wrench 2 mm (7)**:

- 4 1. Tighten the long adjusting screw (a) with a tightening torque of **0.5–0.6 Nm**.
2. Tighten the short adjusting screw (b) with a tightening torque of **0.5–0.6 Nm**.
3. Tighten the **long** adjusting screw (a) **again** with a tightening torque of **0.5–0.6 Nm**.

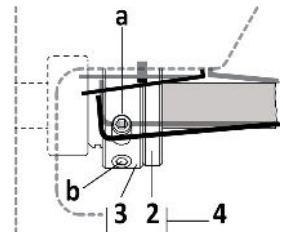

The adjusting ring (3) cannot turn freely at this time.

- 5
  - Do steps 1 thru 4 again to adjust the opposite end position (A or B).
  - Go to step 6 if the two end positions are adjusted.
- 6
  - The procedure to adjust the limit-switch system is completed.



**WARNING**

Do a functional check of the limit-switch system after the two end positions are adjusted.



**CAUTION**

Do not go across adjusted end positions when the motor gearbox is operated manually or with electric tools (externally with the hexagon socket in the electric-motor shaft). This prevents damage to the limit-switch system and an incorrect functional operation.

## 7.4 Installation covers

Always put the covers (2x) and the bolts (2x4 [or 1x4 + 1x3]) back after the work. **Problems with moisture** and/or the IP protection rating (if applicable) must be **prevented!**

- Do a check of the gaskets (2x) for dirt and damages.
- Put gaskets (if removed) back carefully and make sure that no damage is caused.
- Tighten the bolts crosswise and gradually with the correct tightening torque (2x4 [or 1x4 + 1x3]).

Plastic cover \*

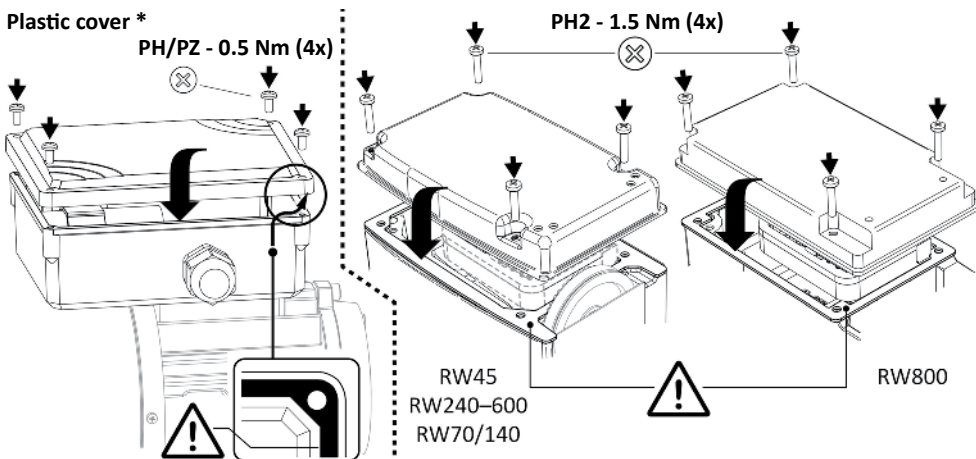

\* Alternatives: Metal cover

TX\SLOT (3x) - 1.0 Nm



PH/(PZ) (4x) - 1.0 Nm

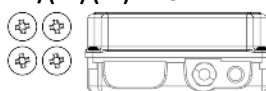

In this manual shown illustrations can be different than the components and/or systems.

## 8. MAINTENANCE INSTRUCTIONS

---

Inspection and maintenance work is only permitted to approved personnel. If necessary remove covers to do the work. Refer to chapter 5.

For safe and correct maintenance, read (if necessary) the (applicable) sections of:

- Chapter 2, chapter 6, chapter 7, chapter 9 and chapter 10.

Always **put removed covers back** after the work! Refer to the end of chapter 7.

### 8.1 Maintenance

---

Maintenance on the RW motor-gearbox is usually not necessary (“maintenance-free”).

#### Maintenance RW45

It is recommended to do the checks that follow every 6 months:

- Of the correct operation of the drive unit and the system
- For **grease** leakage. Tell your installer if there is a leakage
- Of the mechanical condition (wear and tear, output-shaft connections to the operated system, fasteners, correctly attached and such)
- Of the adjusted end positions (are they still correct for the system?).

#### Maintenance RW240/400/600 - RW800 - RW70/140

- **Installation:** After installation interchange the plug in the highest position with the vent plug!

It is recommended to do the checks that follow every 6 months:

- Of the correct operation of the drive unit and the system
- For **oil** leakage (or **grease** leakage\*). Tell your installer if there is a leakage
- Of the mechanical condition (wear and tear, output-shaft connections to the operated system, fasteners, correctly attached and such)
- Of the adjusted end positions (are they still correct for the system?).

\* If a selection from more mounting positions is necessary, RW240 motor gearboxes are also available filled with grease. Refer to §4.2.

Contact your supplier if:

- Replacement of parts is necessary
- A problem is found with no solution. Refer to chapter 9 first.

Refer to the Ridder catalog or the website at **ridder.com** for more information about spare parts (or accessories) that are available. Also refer to available documentation (maintenance instructions) at **ridder.com** of the Ridder products in the operated system.



**Ridder Drive Systems B.V.**

**T** +31 (0)341 416 854 - **F** +31 (0)341 416 611 - **I** [ridder.com](http://ridder.com)

If necessary remove covers to do the work. Refer to chapter 5.

For safe and correct servicing, read the (applicable) sections of:

- Chapter 2, chapter 6, chapter 7 and chapter 10.

Always **put** removed **covers back** after the work! Refer to the end of chapter 7.

### 9.1 Troubleshooting

---

Troubleshooting is only permitted to approved personnel. This section tells about possible malfunctions and their solutions. If a malfunction is not in the list that follows, contact your supplier.

#### **Malfunction 1 The motor gearbox does not turn while the electric motor (EM) is in operation.**

---

Observation 1 The electric motor (EM) turns, while the output shafts of the gearbox do not turn.

---

**Cause 1** The motor gearbox is mechanically defective.

Solution 1 Remove the electric motor (EM). Do a check of the shaft key and replace it if defective. If the shaft key is not defective, then replace the gearbox.

---

#### **Malfunction 2 The direction-of-rotation of the motor gearbox is not correct.**

---

Observation 2 The output shafts turn in the incorrect direction.

---

**Cause 1** The connections on the terminal block of the electric motor are not correct.

Solution 1 **RLS:** Interchange the connections V1 and W1 on the terminal block.  
**RSU:** Interchange the connections V1 and W2 on the terminal block.

---

#### **Malfunction 3 The switching sense of the limit-switch system is not correct.**

---

Observation 3 When the system turns to an end position (A or B), the limit-switch system turns in the direction of the opposite duty switch.

---

**Cause 1** The connections on the connection block/connection blocks of the limit-switch system are not correct.

Solution 1 **RLS:** Interchange the connections 1 and 5 on the connection blocks.  
**RSU:** Interchange the connections 1 and 7 on the connection block.



## 9.2 Technical support

For technical support contact your local After Sales contact person. You can find your local After Sales contact person on our website at [ridder.com](http://ridder.com).

## 10. ENVIRONMENT

### 10.1 Decommissioning and removal

Decommissioning and removal is only permitted to approved personnel.

The starting points that follow are possible:

- 1 During the work it is necessary to de-energize.
- 2 Storage is necessary because of temporary removal.
- 3 The product is at the end of the lifespan.

#### 1 Temporary decommissioning: Work

1. Refer to §2.2 "Precautions and safety instructions".
2. De-energize the product.
3. Do the work (maintenance, service or such).
4. Energize the product.
5. The temporary decommissioning is completed.

#### 2 Temporary decommissioning: Product storage

1. Refer to §2.2 "Precautions and safety instructions".
2. Disconnect the product from the electric circuit.
3. Disconnect the product mechanically from the system and remove the product (usually in opposite sequence of the installation).



**Make sure that the system is in a stable and mechanically tension-free condition and loosened parts (or the system) cannot hit persons! This prevents damage or injury.**

4. Refer to §2.2 "Transport, storage and packaging" and obey the (applicable) instructions and conditions.
5. The temporary decommissioning is completed.

**Note:** Obey the product manual for a subsequent installation!

#### 3 Permanent decommissioning: End of lifespan

1. Refer to §2.2 "Precautions and safety instructions".
2. Disconnect the product from the electric circuit.
3. Disconnect the product mechanically from the system and remove the product (usually in opposite sequence of the installation).



**Make sure that the system is in a stable and mechanically tension-free condition and loosened parts (or the system) cannot hit persons! This prevents damage or injury.**

4. Make the product unserviceable and make a mark on the product. This prevents that the product is (accidentally) used again.
5. The permanent decommissioning is completed. Refer to §10.2 "Waste disposal".



**Ridder Drive Systems B.V.**

**T** +31 (0)341 416 854 - **F** +31 (0)341 416 611 - **I** [ridder.com](http://ridder.com)

## 10.2 Waste disposal

---

Discard products of **Ridder Drive Systems** after their lifespan and obey the applicable national and/or local regulations.

Make sure that after disassembly there is a separation of:

- The collected operating materials (if applicable) such as oil, grease and such
- The different materials (if applicable) such as metals, non-ferrous metals, plastics and such.

It is recommended that approved personnel and/or a company that is specialized in “Waste disposal” do the work.



**Ridder Drive Systems B.V.**

**T +31 (0)341 416 854 - F +31 (0)341 416 611 - I [ridder.com](http://ridder.com)**



**Ridder Drive Systems B.V.**

**T +31 (0)341 416 854 - F +31 (0)341 416 611 - I [ridder.com](http://ridder.com)**



Solutions for  
Controlled Environment Agriculture