

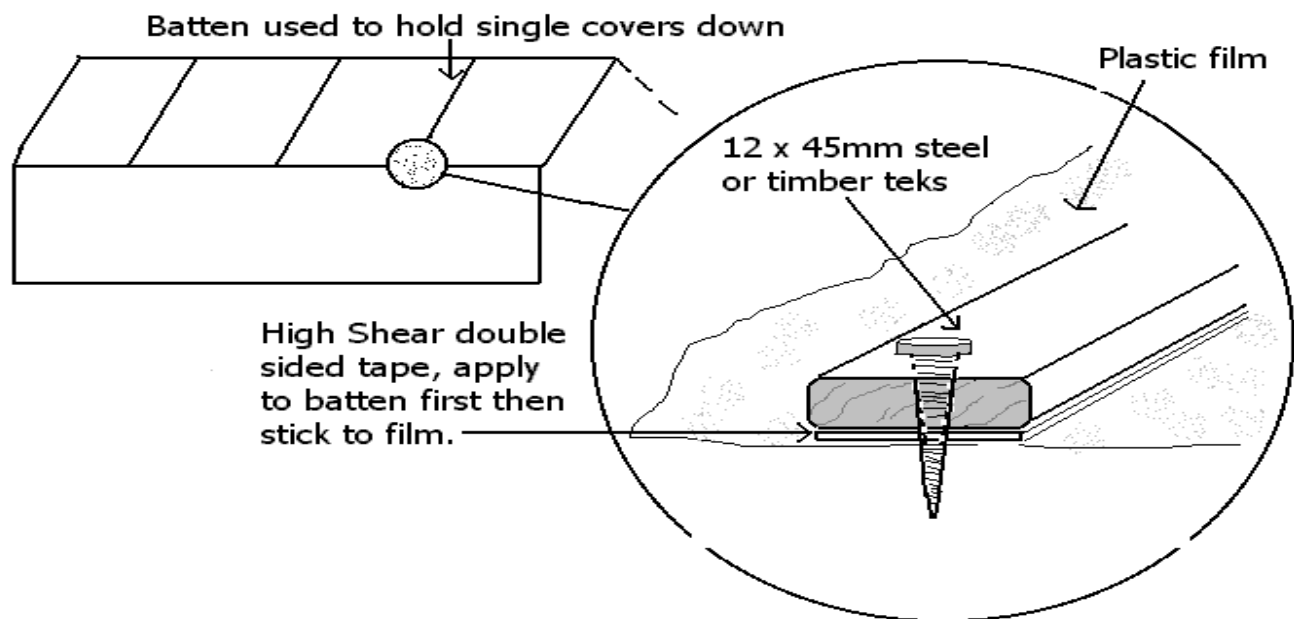

REDPATH BATTEN TAPE

FOR ISOLATING COVERS / BATTENS ON THE STRUCTURE

- Typically a 50mm wide x 19mm thick batten is sufficient. Redpath aluminium battens are available also.
- If timber battens are tanalised, ensure that they are dry and painted white with an acrylic based paint.
- Plane one side of the batten and round the lower edges (face to film)
- Tape should be applied to the full length of the battens lower edge (face to film).
- Install battens onto all rafters plus also ridgelines & end frames in high wind areas
- Do not apply tapes or battens in temperatures below 10° C, or to wet or dirty covers
- Do not install batten until desired final tension on film is achieved
- Use a screw to secure the batten at 200mm intervals through centre of tape
- Batten tape is available in 50mm width to suit differing applications.



Email: admin@redpath.com.au

www.redpath.com.au

Ph: 1 800 024 680