

RPD PolyDrives



The Ridder PolyDrive (RPD) is a compact and lightweight motor gearbox with an integrated limit-switch system for driving manually-controlled or climate-controlled ventilation and screen systems in poly greenhouses. The quick and easy-to-install Ridder PolyDrive is rainproof and windproof. The PolyDrive has a high protection class (IP55) and can be used in an ambient temperature of 0-60 °C.

The low-noise PolyDrive motor gearbox has a gearwheel transmission and a worm wheel transmission, which are integrated in an aluminium precision housing. The self-braking worm wheel transmission ensures that the drive shaft is locked when the reduction gearbox is not running. The fully sealed reduction gearbox has an expansion chamber with a diaphragm to keep the gear oil at a low pressure under all circumstances, even at high temperatures. Thanks to the use of an expansion chamber, the PolyDrive can be installed in any position. There are no restrictions, because there is no need for a bleed plug. The sealed reduction gearbox keeps the gear oil of the PolyDrive in optimal condition for its entire operating lifetime. The PolyDrive is suitable for discontinuous use, operating class s3-35%, with a maximum activation time of 25 minutes.

All PolyDrive motor gearboxes are available with 3-phase, 400 V standard motors (EN 50347). The 150 Nm and 3 rpm PolyDrive motor gearboxes are also available with 3-wire, 1-phase 230 V or 115 V electric motors. The PolyDrive motors have a hexagon in the motor shaft so that the motor gearbox can be driven manually in the event of a power cut.

The RPD drive units are equipped with a linear limit-switch system with duty switches and safety switches. The limit-switch system is, with a transmission, driven by the intermediate shaft of the motor gearbox. The limit-switch system is installed in an integrated chamber and is enclosed by an impact-resistant plastic cover. The limit-switch system is accessible and easy to adjust. The limit-switch system's maximum switching range is 37 or 57 revolutions of the drive shaft. The cabling is connected in spring-clip connections. The PolyDrive has an IP68 M16 x 1.5 cable gland (5-9 mm cable) for the cable feed-through.

The PolyDrive can be optimally controlled by the Ridder MotorControl RMC400. This control system continuously controls, inspects and protects the PolyDrive. To protect the PolyDrive against being overloaded, its electric motors are equipped as standard with a PTC thermistor.

The PolyDrive comes with 16 teeth 5/8"x3/8" sprockets, keys and fasteners. The accompanying chain couplings and assembly plates are available as accessories.

Ridder PolyDrive RPD:

- A drive torque of 150 Nm, 300 Nm or 450 Nm.
 - Rotational speeds of 3 or 5 rpm for a mains frequency of 50 Hz or 3.6 or 6 rpm for a mains frequency of 60 Hz.
 - Protection class IP55.
 - Can be used in ambient temperatures of 0-60°C.
 - Suitable for discontinuous use, operating class s3-35%, maximum activation time 25 minutes.
 - Equipped as standard with 16-tooth galvanised chain coupling 5/8"x3/8".
 - RPD150, 300 and 400 available with 3-phase, 400 V standard motors (EN 50347).
 - RPD150, 300 and 400 available with 3-phase wide voltage electric motors with CSA and/or UL approval, 208-415 V at 50/60 Hz, 415-480V at 60 Hz.
 - RPD150 / 3 rpm also available with 3-wire, 1-phase 230 V or 115 V electric motors.
 - Electric motors eventually protected by PTC.
-
- Maximum switching range of limit-switch system 36 or 61 revolutions of the drive shaft.
 - IP68 M16x1.5 cable gland for cable feedthrough (5-9 mm cable).
 - Optionally controlled by Ridder MotorControl RMC400.

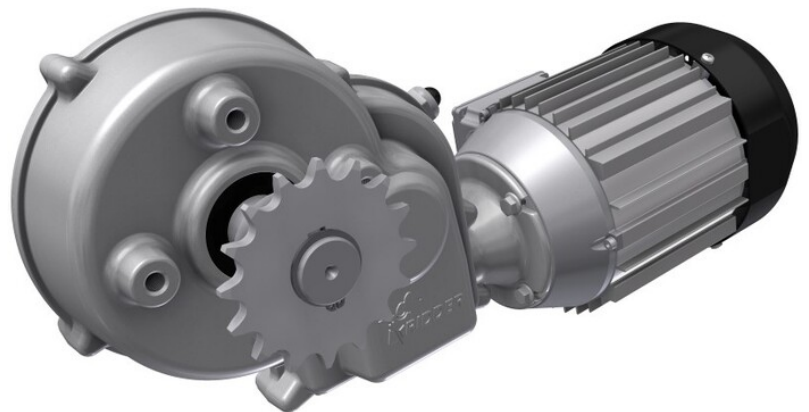

RPD PolyDrives



RPD PolyDrives



Item no.	Description	[m]	[M] 50Hz	[n] 50Hz	[M] 60Hz	[n] 60Hz	EM	F -	PTC	CCC C/U	EM nr
		kg	Nm	/min	Nm	/min					
506110	RPD150-3-18\400\36\3C\5/8-16	15	150	3	150	3,6	A	3		CCC	754021
506310	RPD150-5-25\400\61\3C\5/8-16	15,0	150	5	150	6	A	3		CCC	754031
506340	RPD150-5-25\208-480\61\P\CU\5/8-16	15	150	5	150	5,9	B	3	•	CUL	764022
506370	RPD150-6-25\380\60\61\5/8-16	15			150	6	J	3		CCC	754131
506250	RPD150-3.6-18\115\36\CU\5/8-16	15			150	3,6	F	1	•	CUR	761219
506210	RPD150-3-18\230\36\5/8-16	15	150	3	150	3,6	D	1			761018
506410	RPD150-5-25\230\61\CU\5/8-16	15	150	5	150	6	D	1	55	CUR	761024
506120	RPD300-3-25\400\36\3C\5/8-16	15	300	3	300	3,6	A	3		CCC	754031
506150	RPD300-3-25\208-480\36\P\CU\5/8-16	15	300	3	300	3,5	B	3	•	CUL	764022
506180	RPD300-3.6-25\380\60\36\5/8-16	15,7			300	3,6	J	3		CCC	754131
506320	RPD300-5-37\400\61\3C\5/8-16	15	300	5	300	6,1	A	3	•	CCC	754041
506350	RPD300-5-37\208-480\61\P\CU\5/8-16	15	300	5	300	6,1	B	3	•	CUR	764032
506380	RPD300-6-40\380\60\61\5/8-16	15			300	6	J	3	•	CCC	754141
506260	RPD300-3.6-25\115\36\CU\5/8-16	15			150	3,6	G	1	•	CUR	761222
506450	RPD300-6-37\115\61\CU\5/8-16	15			300	5	G	1	•	CUR	761232
506220	RPD300-3-25\230\36\CU\5/8-16	15	300	3	300	3,5	E	1	55	CUR	761024
506420	RPD300-5-37\230\61\C\5/8-16	15	300	5	300	6	E	1	•	C	761032
506130	RPD450-3-37\400\36\3C\5/8-16	15,7	450	3	450	3,7	A	3		CCC	754041
506160	RPD450-3-37\208-480\36\P\CU\5/8-16	15,7	450	3	450	3,7	B	3	•	CUR	764032
506190	RPD450-3.6-40\380\60\36\5/8-16	15			450	3,6	J	3	•	CCC	754141
506290	RPD450-3.6-44\600\36\C\5/8-16	15,7			450	3,6	C	3		C	763632
506270	RPD450-3.6-37\115\36\CU\5/8-16	15,7			450	3,6	G	1	•	CUR	761232
506230	RPD450-3-37\230\36\CU\5/8-16	15	450	3	450	3,6	E	1	•	C	761032